

SWSI centrifugal fans



Pacific Ventilation Pty Ltd certifies that the Model AWP Centrifugal fans shown herein are licensed to bear the AMCA Seal. The ratings shown are based on tests and procedures performed in accordance with AMCA Publication 211 and AMCA Publication 311 and comply with the requirements of the AMCA Certified Ratings Program.



Table of contents

Ordering information	1
General information	2
Fan selection – ordering requirements	3
Fan laws	4
Fan arrangements	5
Designation of direction of rotation and positions of fan parts	6-7
Temperature and altitude deration	8
System effects	9-13
Accessories / ancillaries	14-15
Vibration Isolators	15
Performance tables Single inlet – single width (SWSI)	16-32
Fan arrangements and dimensions	33
Fan weights	34
Metric and imperial conversion factors	35

Important note:

Please note that when and where it necessitate improvements to our fans, we reserve the right to change designs, dimensions and/or constructional aspects of the fans.

Ordering information

Fan Specifications			
1 Fan Type	<input type="checkbox"/> SWSI <input type="checkbox"/> DWDI		
2 Model & Size. Example ASP 500 SWSI	<input type="checkbox"/> Model : _____		
3 Drive configuration	<input type="checkbox"/> Belt <input type="checkbox"/> Direct <input type="checkbox"/> Coupling <input type="checkbox"/> Others : _____		
4 Arrangement	<input type="checkbox"/> Bare Fan		
4 1) 1 & 3 – Bare shaft 2) 4, 5, 7 & 8 for complete with drive system	<input type="checkbox"/> Complete with drive system		
5 Rotation & Discharge. Example LG90....	<input type="checkbox"/> LG <input type="checkbox"/> 0 <input type="checkbox"/> 45 <input type="checkbox"/> 90 <input type="checkbox"/> 135 <input type="checkbox"/> 180 <input type="checkbox"/> 270 <input type="checkbox"/> 315 <input type="checkbox"/> RD <input type="checkbox"/> 0 <input type="checkbox"/> 45 <input type="checkbox"/> 90 <input type="checkbox"/> 135 <input type="checkbox"/> 180 <input type="checkbox"/> 270 <input type="checkbox"/> 315		
6 Motor location (refer to page 6) Example. W...	<input type="checkbox"/> W <input type="checkbox"/> X <input type="checkbox"/> Y <input type="checkbox"/> Z		
7 Air flow rate	Q : <input type="checkbox"/> L/S <input type="checkbox"/> m ³ /h <input type="checkbox"/> m ³ /min <input type="checkbox"/> m ³ /s <input type="checkbox"/> cfm		
8 Static pressure or Total pressure	SP : _____ TP : _____ <input type="checkbox"/> Pa <input type="checkbox"/> mmH ₂ O <input type="checkbox"/> inWG		
9 Fan RPM	Maximum : _____ Minimum : _____ <input type="checkbox"/> dB <input type="checkbox"/> dBA		
10 Noise level	Lw : _____ Lp : _____ At Distance : _____ <input type="checkbox"/> Free field <input type="checkbox"/> Room condition <input type="checkbox"/> Corner / wall		
11 Ambient temperature	<input type="checkbox"/> °C or <input type="checkbox"/> °F		
12 Air density, if condition is different from standard	<input type="checkbox"/> Density : _____ kg/m ³ <input type="checkbox"/> Altitude : _____ m		
Motor Specifications		Ancillaries & Fittings	
13 Power	<input type="checkbox"/> HP : _____ <input type="checkbox"/> kW: _____ <input type="checkbox"/> 2P <input type="checkbox"/> 4P <input type="checkbox"/> 6P <input type="checkbox"/> 8P	20	Note : <input type="checkbox"/> Inspection Door <input type="checkbox"/> Drain Plug <input type="checkbox"/> Flexible Duct <input type="checkbox"/> Inlet Vane Duct <input type="checkbox"/> Vibration Isolators : <input type="checkbox"/> Rubber <input type="checkbox"/> Spring <input type="checkbox"/> Floor Mounted <input type="checkbox"/> Ceiling Hang <input type="checkbox"/> Silencers : <input type="checkbox"/> With Pod <input type="checkbox"/> Without Pod <input type="checkbox"/> Inlet <input type="checkbox"/> Outlet <input type="checkbox"/> Both Inlet & Outlet <input type="checkbox"/> Counter Flange
14 No. of Poles / RPM	Other : _____ (state RPM)		
15 Voltage	<input type="checkbox"/> 220V <input type="checkbox"/> 415V <input type="checkbox"/> 380V <input type="checkbox"/> 440V <input type="checkbox"/> 400V <input type="checkbox"/> Other : _____		
16 Phase	<input type="checkbox"/> 1 Phase <input type="checkbox"/> 3 Phase	Fan Location : <input type="checkbox"/> Indoor <input type="checkbox"/> Outdoor <input type="checkbox"/> Flat <input type="checkbox"/> L-Type <input type="checkbox"/> U-Type <input type="checkbox"/> Inlet <input type="checkbox"/> Outlet	
17 Frequency	<input type="checkbox"/> 50 Hz <input type="checkbox"/> 60 Hz	21	
18 Frame size	<input type="checkbox"/> IEC : _____ <input type="checkbox"/> NEMA : _____ <input type="checkbox"/> Others : _____	Note : <input type="checkbox"/> Painting <input type="checkbox"/> Powder Coating <input type="checkbox"/> Hot dipped galvanising <input type="checkbox"/> Anti Spark <input type="checkbox"/> Corrosion resistant <input type="checkbox"/> Heat resistant, Temp : _____ <input type="checkbox"/> Smoke Spill, Max. Temp :- _____ For _____ Hour	
19 Brand, if specified	<input type="checkbox"/> Brand : _____ <input type="checkbox"/> Mfg. : _____ <input type="checkbox"/> Country : _____		

General information



ASP Single inlet centrifugal fan

Pacific Ventilation's range of centrifugal fans offer the engineers the flexibility to choose the most suitable sizes and configurations to suit any site condition. With over 2000 variations of diameter, width and length type, specifications are virtually tailor-made to individual needs.

Casings are made of mild steel, welded and many are of semi-universal construction allowing the discharge angle to be modified to suit customer's requirements. Many additional features and ancillaries can be supplied on request, example; split casings, carbon steel and stainless steel impellers.

Backward inclined blades:

Non-overloading power characteristic suitable for very light dust applications (e.g. clean side of dust collector) where a good efficiency is required. Used for high pressure ventilation systems or where the system resistance could fluctuate. Normal discharge velocities 1800-3000 feet per minute.

Fan selection – ordering requirements

There are a number of factors which influence the selection of a fan. It is impossible to formulate firm rules governing the selection. However, we can try to obtain the best compromise to achieve the required performance in the most economical way.

Comprehensive information for selecting the most suitable fan for an application or duty is contained in the performance tables.

All performance data given in this publication are for standard conditions. These assume a gas density of 1.2 kg/m³ which is equivalent to air at a temperature of 16°C, a barometric pressure of 100 kPa. Other conditions which also meet requirements are dry air at a temperature of 20°C and a barometric pressure of 101.325 kPa.

Flowrate : Actual volume of gas per unit time measured at the fan inlet and quoted in m³/s or ft³/min.

Pressure : Fan static pressure in force per unit area between inlet and outlet and quoted in kPa, mm or in w.g.

Gas density : At fan inlet in mass per unit volume and quoted in kg/m³.

Altitude : Of working site (if over 300m) and quoted in metres.

Nature of gas : Composition (if not air); temperature at which flowrate, pressure, and gas density apply, quoted in °C; temperature range (max and min); quantity of entrained solids; and details of erosive, corrosive, explosive, or toxic constituents.

Fan type : Details of blade configuration where important for correct operation, size of connecting ducts, handling, and discharge.

Drive arrangements : Where this affects the selection (e.g. limiting to a direct drive speed, proximity of inlet obstructions (especially DIDW fans), etc).

All performance figures must be corrected to those pertaining at the fan inlet. The user must be certain under what conditions the specified duty has been measured.

Fan static pressure kPa.

$$= \text{Actual pressure} \times \frac{\text{Standard air density}}{\text{Inlet density}} \quad i$$

Table 1

Wet bulb temperature t _{wi} °C	0	5	10	15	20	25	30	35
Constant Z	.0023	.0033	.0047	.0065	.0087	.012	.0162	.0213

Table 2 Variation in air condition with altitude

Altitude (metres)	Barometric pressure (kPa)	Temperature (°C)	Air Density (kg/m ³)
-250	104.4	17	1.25
Sea level	101.3	15	1.22
250	98.4	13	1.20
500	95.5	12	1.17
750	92.6	10	1.14
1000	89.9	8	1.11
1500	84.6	5	1.06
2000	79.5	2	1.00
3000	70.1	-4	0.91
4000	61.6	-11	0.82
6000	47.2	-24	0.66
8000	35.6	-37	0.53
10000	26.4	-50	0.41
20000	5.5	-56	0.088
30000	1.2	-66	0.018

For ordinary purposes, measurement of the barometric pressure at inlet p_i kPa and the dry bulb temperature t_i °C is sufficient, the inlet density being

$$i = 1.20 \left(\frac{289}{273 + t_i} \right) \left(\frac{p_i}{100} \right) \text{ kg/m}^3$$

For air of high humidity the inlet density is approximately

$$i = 1.205 \left(\frac{289}{273 + t_i} \right) \left[\left(\frac{p_i}{100} \right) \left(1 + \frac{t_i - t_{wi}}{4000} \right) - Z \right] \text{ kg/m}^3$$

Where t_{wi} = wet bulb temperature °C

Z = constant obtained from table 1

Where the resistance on the inlet side of the fan is greater than about 5 kPa, the air will become attenuated. This will affect the inlet density relative to outside ambient air. It will also mean that the volume flowrate at the fan inlet will be greater than that at the entry to the duct system, and the pressure which the fan can develop will reduce correspondingly. Again it is necessary to know under exactly what conditions the quantities have been measured.

$$\text{Inlet Density } i = 1.2 \times \text{SG} \times \frac{100 - \text{Psi}}{100} \times \frac{289}{273 + t_i}$$

Where Psi = static pressure at fan inlet kPa

SG = specific gravity of gas (if different) relative to air (SG = 1)

Note : Inlet density will also be reduced by the effects of altitude. The table gives the variation of air conditions with altitude and is based on the Standard Atmosphere of the International Civil Aviation Organisation. This is a representative average for temperature latitudes.

Fan laws

FANS are usually made in a geometrically similar range of sizes and can be run at an infinite number of rotational speeds.

Certain laws govern the relative performance of these fans when working at the same point on the pressure-volume characteristic and may be stated briefly as follows :

Thus if a fan is applied to a system and its speed is changed from N_1 to N_2 then : (with constant impeller size)

$$Q \quad N \text{ ie } Q_2 = Q_1 \times \frac{N_2}{N_1} \quad - \text{ Volume flow varies directly as the speed of rotation.}$$

$$p \quad N^2 \text{ ie } p_2 = p_1 \times \left(\frac{N_2}{N_1}\right)^2 \quad - \text{ Pressure developed varies as (speed of rotation)}^2$$

$$P \quad N^3 \text{ ie } P_2 = P_1 \times \left(\frac{N_2}{N_1}\right)^3 \quad - \text{ Absorbed power varies as (speed of rotation)}^3$$

An increase of 10% in fan rotational speed will therefore increase volume flow Q by 10%, pressure developed p by 21% but power absorbed P by 33%, assuming air/gas density is unchanged. Unless large motor margins over the absorbed power are available, therefore, the possibilities of increasing flow by speed increase are usually limited.

At the same speed and gas density, a fan of a different size will have a performance as given below :

$$Q \quad D^3 \text{ ie } Q_2 = Q_1 \times \left(\frac{D_2}{D_1}\right)^3 \quad - \text{ Volume flow varies as (impeller size)}^3$$

$$p \quad D^2 \text{ ie } p_2 = p_1 \times \left(\frac{D_2}{D_1}\right)^2 \quad - \text{ Pressure developed varies as (impeller size)}^2$$

$$P \quad D^5 \text{ ie } P_2 = P_1 \times \left(\frac{D_2}{D_1}\right)^5 \quad - \text{ Absorbed power varies as (impeller size)}^5$$

At the same tip speed and gas density, $N_1 D_1$ will equal $N_2 D_2$ (Varying flows varies as (speed of rotation) and impeller size)

$$Q_2 = Q_1 \times \frac{N_2}{N_1} \times \left(\frac{D_2}{D_1}\right)^3 \quad - \text{ Volume flows varies as (speed of rotation) x (impeller size)}^3$$

$$\text{but then } \frac{N_2}{N_1} = \frac{D_1}{D_2}$$

$$Q_2 = Q_1 \times \left(\frac{D_2}{D_1}\right)^2$$

$$\text{also } p_2 = p_1 \times \left(\frac{N_2}{N_1}\right)^2 \times \left(\frac{D_2}{D_1}\right)^2 \quad - \text{ Pressure developed varies as (speed of rotation)}^2 \times (\text{impeller size})^2$$

$$p_2 = p_1$$

$$\text{and } P_2 = P_1 \times \left(\frac{N_2}{N_1}\right)^3 \times \left(\frac{D_2}{D_1}\right)^5 \quad - \text{ Absorb power varies as (Speed of rotation)}^3 \times (\text{impeller size})^5$$

$$P_2 = P_1 \times \left(\frac{D_2}{D_1}\right)^2$$

Thus, at constant tip speed and gas density, the approximate increase per size will be 25% on both capacity and power for the same pressure. The speed will be reduced by 11%.

Fan arrangements

Arrangement 1
Single inlet pedestal

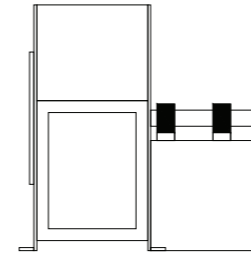

For belt drive. Impeller overhung. Two bearings on full-depth pedestal.

Arrangement 2
Single inlet overhung

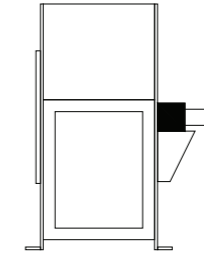

For belt drive. Impeller overhung. Bearings on bracket, supported by fan housing.

Arrangement 3
Single inlet bearer bar

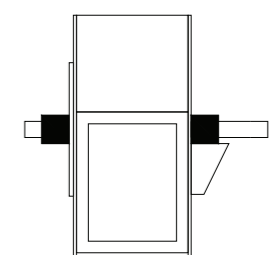

For belt drive. One bearing on each side of casing, supported by bearer bars.

Arrangement 4
Single inlet direct drive and stool

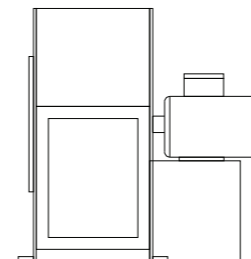

For direct drive. Impeller overhung on motor shaft. No bearings on fan. Motor feet supported by full depth-pedestal.

Arrangement 5
Single inlet direct drive, no stool

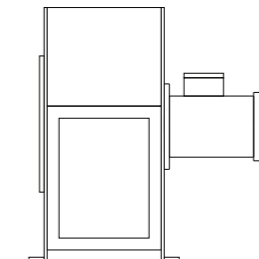

For direct drive. Impeller overhung motor shaft. No bearings on fan. Motor bolted to fan casing by its flanged end shield.

Arrangement 6
Double inlet bearer bar

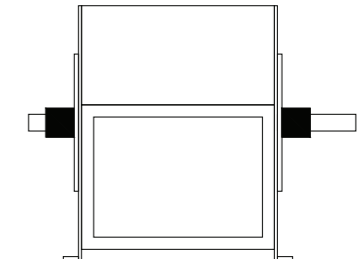

Double inlet, double width fan for belt drive. One bearing in each inlet, supported by bearer bars.

Arrangement 7
Double inlet coupling

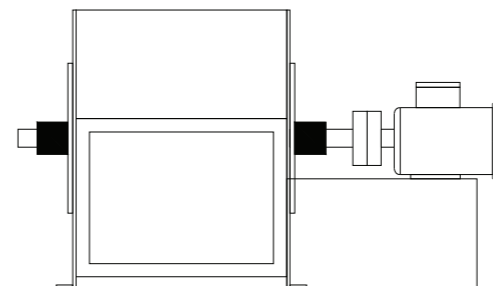

Double inlet, double width fan for coupling drive. Generally as arrangement 6, plus pedestal for the motor.

Arrangement 8
Single inlet coupling

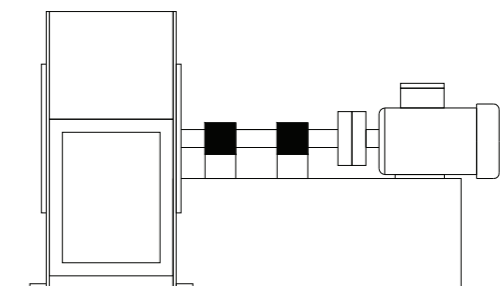

For coupling drive. Generally as arrangement 1 but pedestal extended to receive motor.

Designation of direction of rotation and positions of fan parts

The following conventions have been established for the designation of direction of rotation of the fan and the positions of some of its parts, in accordance with Eurovent Document 1/1

Direction of rotation

The direction of rotation is designated clockwise (right hand, symbol RD) or counter-clockwise (left hand, symbol LG) according to the direction seen when viewed along the axis of the fan from the side opposite to the inlet. By this convention the direction of rotation is determined according to the airflow into the inlet and regardless of motor position.

Note : For a double-inlet centrifugal fan the direction of the rotation is determined when viewed from the drive side.

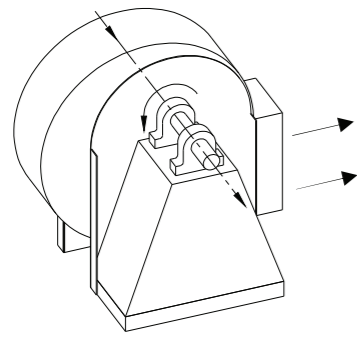

LG : counter-clockwise rotation

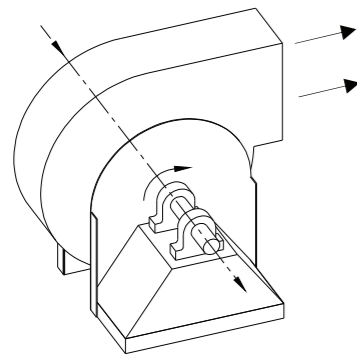

RD : clockwise rotation

Direction of rotation of centrifugal fans

Angular position of parts of the fan assembly

The angular positions of parts of a fan are defined in relation to an origin taken as a straight line perpendicular to the mounting base towards the axis of rotation.

Outlet position of a centrifugal fan

The outlet position of a centrifugal fan is designated by the symbol for the direction of rotation (i.e. LG or RD) followed by the angle in degrees between the origin and the axis of the discharge measured in the direction of rotation e.g. LG135 or RD 90.

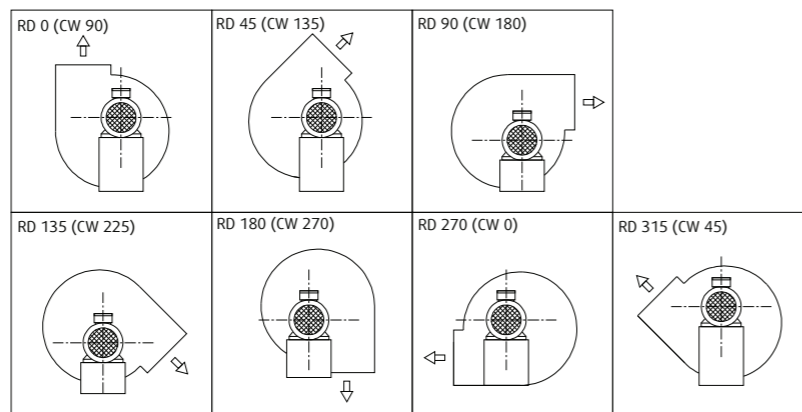
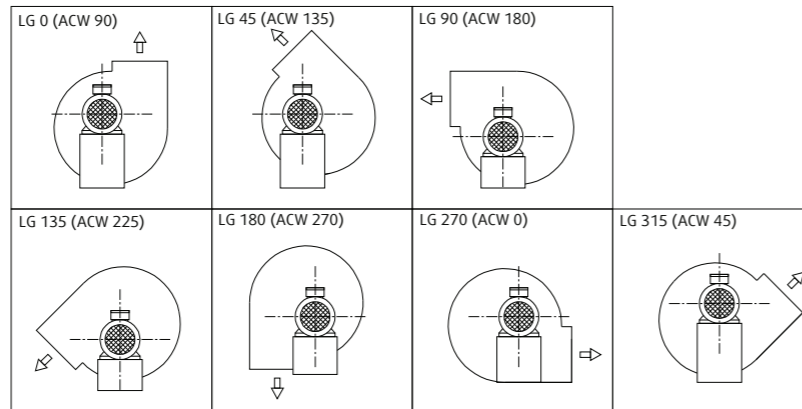
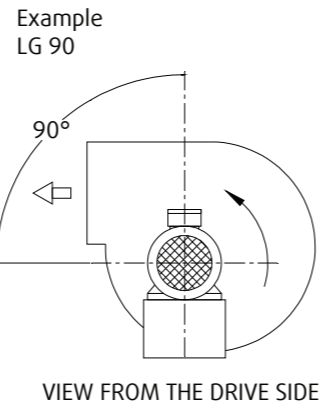

Standard discharge positions for centrifugal fans

Position of component parts of a centrifugal fan with volute casing

The angular position of a motor, inlet box or bend, inspection door or other component, is designated by the symbol for the direction of rotation (i.e. LG or RD) followed by the angle in degrees between the origin and the axis of the component part measured in the direction of rotation.

Note : Where the fan casing is not provided with feet the outlet position will be taken as 0°.

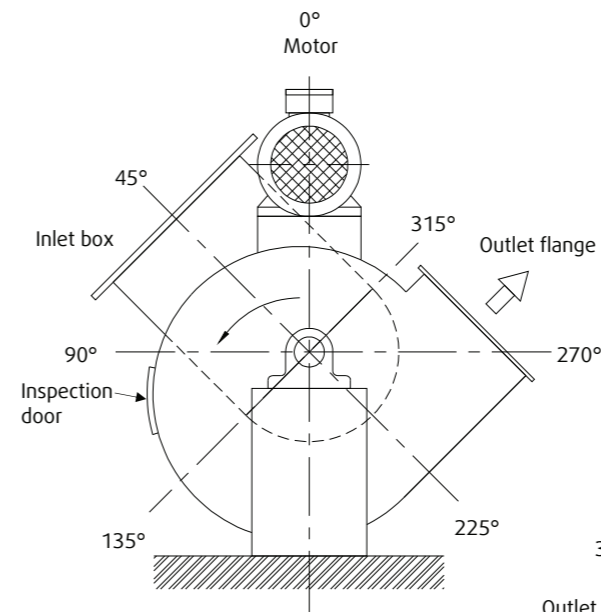

Example I

Outlet Flange : LG 315
Inspection Door : LG 135
Inlet Box : LG 45
Motor : LG 0

Position of components of a centrifugal fan with volute casing

Plan view position of motor for belt or chain drive

The position of a motor when viewed perpendicular to the mounting base is denoted by letters W, X, Y, Z, as shown below and it has to be specified whether the drive is on the inlet side or on the side opposite to the inlet.

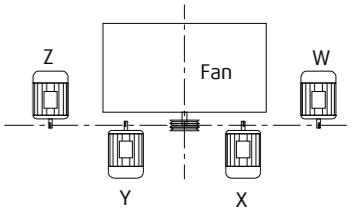

Note : The angular position of a motor may be indicated as explained on the right.

Method of designation of the alternative positions in plan view of a motor for belt or chain drive. Positions W and Z are standard, positions X and Y are only available to special order.

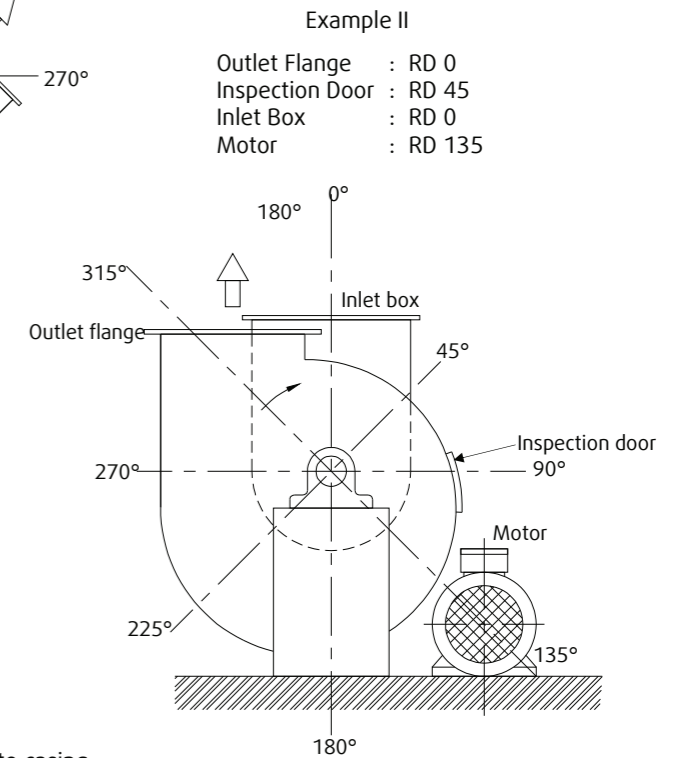

Temperature and altitude deration

All performance data given in this catalogue are for standard inlet conditions. These assume a gas density of 1.2 kg/m³, dry air at a temperature of 20° C and a barometric pressure of 101.325 kPa

It is advisable for the user to ascertain the conditions under which the fan is to be subjected i.e. to enable necessary deration for a more precise fan selection.

Operating temperature effects the fan pressure and also the power. Thus the fan static pressure must be corrected accordingly.

An example how this is done is as follows :

A customer required a fan for duty of 7.39 m³/s @ 101.6mm w.g. at 150 m above sea level and at an elevated temperature of 90° C. From **table 1** at a temperature of 90° C and altitude of 150 m we have a factor at 1.25. With this factor the new static pressure is 101.6 x 1.25 = 127 mm w.g.

With 7.39 m³ / s at 127mm w.g. we now select the fan from the performance tables.

An AS 100 SWSI running at 906 rpm requiring 11.73 kw would be a suitable choice. Now we have to correct the brake kw.

$$11.73 \div 1.25 = 9.38 \text{ kw.}$$

This would then be the required power at the operating condition.

Table 1

Temp 0° C	ALTITUDE IN METRES ABOVE SEA LEVEL										
	0	150	300	450	600	750	900	1050	1200	1350	1500
20	0.97	1.02	1.03	1.05	1.07	1.09	1.11	1.13	1.14	1.16	1.18
30	1.04	1.05	1.06	1.08	1.10	1.12	1.14	1.16	1.18	1.20	1.22
40	1.07	1.08	1.10	1.12	1.14	1.16	1.18	1.20	2.22	2.24	2.26
50	1.11	1.12	1.13	1.15	1.17	1.19	1.21	1.23	1.25	1.27	1.30
60	1.13	1.15	1.17	1.19	1.21	1.23	1.25	1.27	1.29	1.32	1.33
70	1.16	1.18	1.20	1.22	1.24	1.26	1.28	1.31	1.33	1.35	1.37
80	1.19	1.22	1.24	1.26	1.28	1.30	1.32	1.35	1.38	1.40	1.42
90	1.22	1.25	1.27	1.30	1.32	1.34	1.36	1.38	1.41	1.43	1.45
100	1.25	1.29	1.31	1.33	1.35	1.38	1.40	1.42	1.45	1.48	1.51
125	1.34	1.38	1.40	1.42	1.45	1.47	1.50	1.53	1.56	1.58	1.60
150	1.43	1.46	1.48	1.51	1.53	1.56	1.59	1.62	1.65	1.68	1.71
175	1.52	1.55	1.57	1.60	1.62	1.66	1.69	1.72	1.75	1.78	1.81
200	1.60	1.64	1.66	1.69	1.72	1.75	1.79	1.82	1.85	1.88	1.91
225	1.69	1.72	1.74	1.77	1.80	1.84	1.88	1.92	1.95	1.99	2.05
250	1.78	1.81	1.83	1.86	1.89	1.93	1.97	2.00	2.04	2.08	2.12
275	1.86	1.90	1.92	1.95	1.99	2.03	2.07	2.10	2.14	2.18	2.22
300	1.95	1.98	2.00	2.04	2.08	2.12	2.16	2.20	2.24	2.28	2.32
325	2.03	2.07	2.10	2.14	2.18	2.22	2.26	2.30	2.34	2.38	2.42
350	2.12	2.16	2.18	2.22	2.26	2.30	2.34	2.38	2.43	2.47	2.51
375	2.20	2.24	2.27	2.31	2.35	2.40	2.44	2.48	2.52	2.56	2.60
400	2.29	2.33	2.35	2.41	2.45	2.49	2.53	2.57	2.62	2.67	2.72
425	2.37	2.42	2.46	2.50	2.54	2.59	2.63	2.67	2.72	2.77	2.82
450	2.45	2.50	2.54	2.58	2.63	2.68	2.72	2.77	2.82	2.87	2.92

System effects

Despite the need to establish good inlet and outlet conditions, it has to be recognised that there will be many installations where lack of space or site geometry will preclude the fitting of ideal duct connections. The information which follows is intended to assist the designer in assessing the likely effects of less than ideal ducting. As an alternative, it also indicates the preferred amounts of straight ducting necessary on fan inlet and outlet.

Normally the system designer will have access to information giving the pressure loss in fittings expressed as some fraction of the local velocity pressure. These losses always assume a fully developed and symmetrical velocity profile. Where fittings are adjacent to the fan inlet or outlet, an additional effect may be anticipated as the profile may be far from this ideal. The additional loss is given in the 'approximate' information in this section.

Inlet connections

Swirl and non-uniform flow can be corrected by straightening or guide vanes. Restricted fan inlets located too close to walls or obstructions or restrictions caused by fans inside a cabinet, will decrease the usable performance of a fan. The clearance effects is considered a component part of the entire system and the pressure losses through the cabinet must be considered a system effect when determining system characteristics.

Fig 3. shows the variations in inlet flow which will occur. A ducted inlet condition is as (i), the unducted conditions as (ii), and the effect of a bellmouth inlet as (vi). Flow into a sharp edged duct as shown in (iii) or into an inlet without a smooth entry as shown in (iv) is similar to flow through a sharp edged orifice in that vena contracta is formed. The reduction in flow area caused by the vena contracta and the following rapid expansion causes a loss which should be considered a system effect.

Wherever possible fans with open inlet should be fitted with 'bell-mouths' as (vi). If it is not practical to include such a smooth entry, a converging taper will substantially diminish the loss of energy and even a simple flat flange on the end of a duct will reduce the loss to about one half of the loss through an unflanged entry. The slope of transition elements should be limited to an included angle 30° when converging or 15° when diverging.

Non-uniform flow into the inlet is the most common cause of deficient fan performance. An elbow or a 90° duct turn located at the fan inlet will not allow the air to enter uniformly and will result in turbulent and uneven flow distribution at the fan impeller. Air has weight and a moving air stream has momentum and the air stream therefore resists a change in direction within an elbow as illustrated.

The system effects for elbows of given radius diameter ratios are given in Fig 4 - 6. These losses only apply when the connection is adjacent to the fan inlet and are additional to the normal loss.

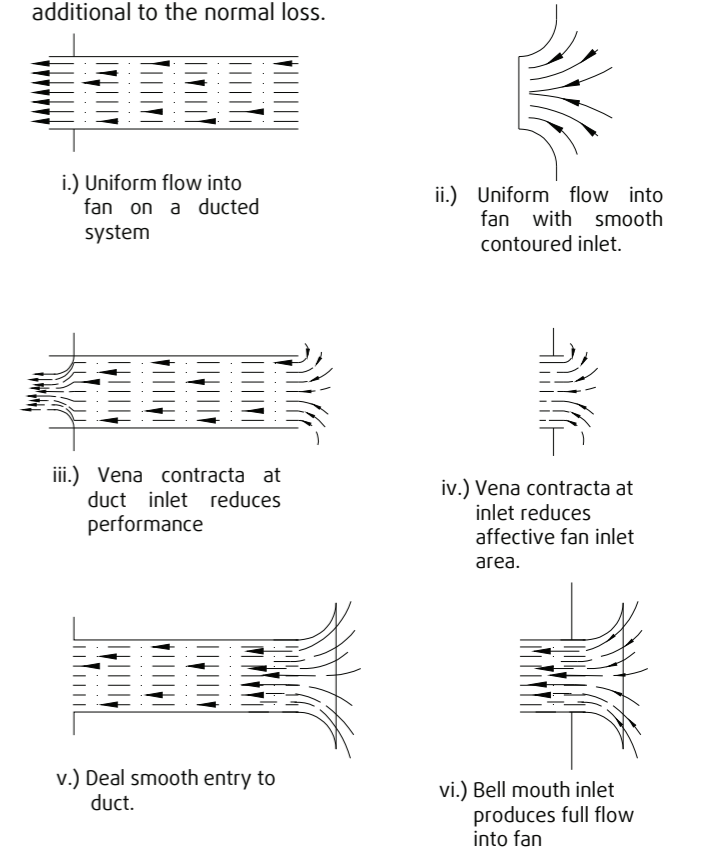
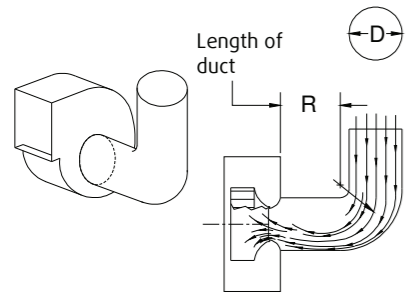

Fig 3. Typical inlet connections for centrifugal fans.



R/H	No duct	2D duct	5D duct
0.75	1.5	0.8	0.4
1.0	1.2	0.7	0.3
2.0	1.0	0.6	0.2
3.0	0.7	0.4	0.2

Fig. 4

Fig. 4 System effects expressed as velocity pressures. Non-uniform flow into a fan from a 90° round section elbow, no turning vanes.

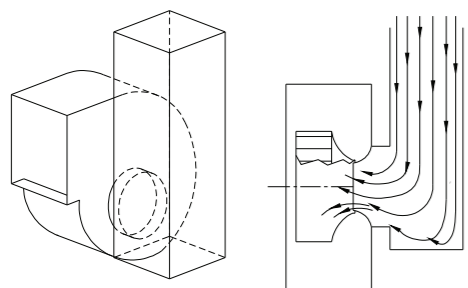
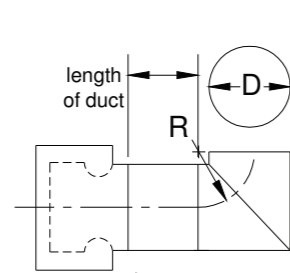

Fig. 5

Fig. 5 System effects expressed as velocity pressures. Non-uniform flow into a fan from a rectangular inlet duct. The reduction in capacity and pressure for this type of inlet condition are difficult to tabulate. The many differences in width and depth of duct influence the reduction in performance to varying degrees. Such inlets should therefore be avoided. Capacity losses of 45% have been observed. Existing installations can be improved with guide vanes or the conversion to square or mitred elbows with guide vanes.

Fig. 6 System effects of ducts of given radius/diameter ratios expressed as velocity pressures. Note : the inside area of the square duct (H x H) is equal to the inside area circumscribed by the inlet fan spigot. The maximum included angle of any converging element of the transition should be 30°, and for diverging element 15°



a) Two piece mitred 90° round section elbows – no vanes

R/H	No duct	2D duct	5D duct
-	3.0	3.0	1.0

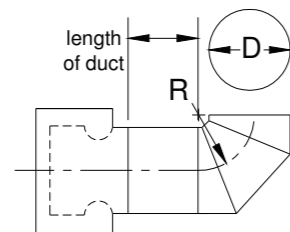

b) Three piece mitred 90° round section elbow – no vanes

R/H	No duct	2D duct	5D duct
0.5	2.5	1.5	0.8
0.75	1.5	1.0	0.5
1.0	1.2	0.7	0.3
2.0	1.0	0.5	0.3
3.0	0.8	0.5	0.3

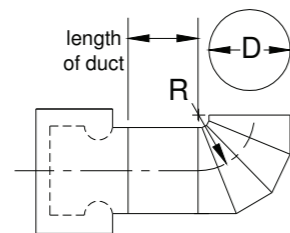

c) Four or more piece mitred 90° round section elbow – no vanes

R/H	No duct	2D duct	5D duct
0.5	1.8	1.0	0.5
0.75	1.5	0.8	0.4
1.0	1.3	0.7	0.3
2.0	1.0	0.5	0.3
3.0	0.7	0.4	0.2

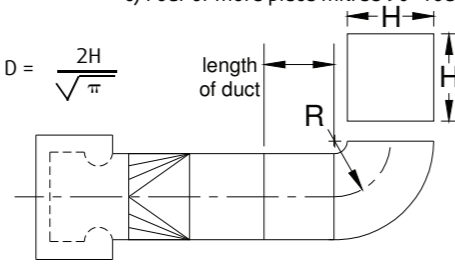

a) Square elbow with inlet transition – no turning vanes

R/H	No duct	2D duct	5D duct
0.5	2.5	1.6	0.8
0.75	2.0	1.5	0.7
1.0	1.5	0.7	0.3
2.0	0.8	0.5	0.2

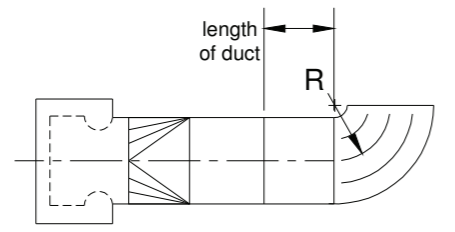

b) Square elbow with inlet transition – three long turning vanes

R/H	No duct	2D duct	5D duct
0.5	0.8	0.5	0.3
1.0	0.5	0.3	0.2
2.0	0.3	0.3	0.1

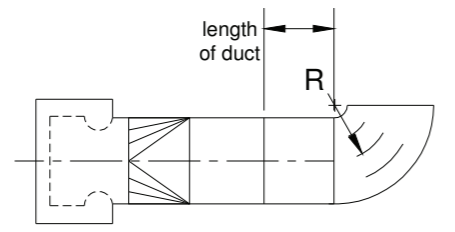

c) Square elbow with inlet transition – short turning vanes

R/H	No duct	2D duct	5D duct
0.5	0.8	0.5	0.3
1.0	0.5	0.6	0.2
2.0	0.3	0.3	0.1

Fig. 6

Inlet swirl Another cause of reduced performance is an inlet duct which produces a vortex in the air stream entering a fan inlet. An example of this condition is shown.

The ideal inlet duct is one which allows the air to enter axially and uniformly without swirl in either direction. Swirl in the same direction as the impeller rotation reduces the pressure-volume curve by an amount dependent upon the intensity of the vortex. The effect is similar to the change in the pressure volume curve achieved by inlet vanes installed in a fan inlet which induce a controlled swirl and so vary the volume flow. Contra-swirl at the inlet will result in a slight increase in the pressure-volume curve but the horsepower will increase substantially.

Inlet swirl may arise from a variety of conditions and the cause is not always obvious. Some common duct connections which cause inlet swirl are illustrated.

Inlet turning vanes Where space limitations prevent the use of optimum fan inlet connections, more uniform flow can be achieved by the use of turning vanes in the inlet elbow. Many types are available from a single curved sheet metal vane to multi bladed aerofoils.

The pressure drop through the vanes must be added to the system pressure losses. These are published by the manufacturer, but the catalogued pressure loss will be based upon uniform air flow at entry. If the air flow approaching the elbow is non-uniform because of a disturbance further up the system, the pressure loss will be higher than published and the effectiveness of the vanes will be reduced.

Straighteners Air flow straighteners (egg crates) are often used to eliminate or reduce swirl in a duct. An example of an egg-crate straightener is shown in Fig 10.

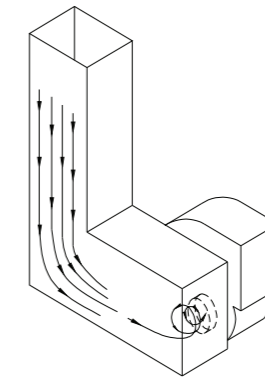

Fig. 7 Loss of performance due to inlet swirl

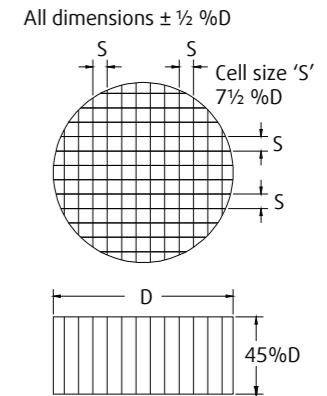

Fig. 10 Example of 'egg crate' air flow straighteners.

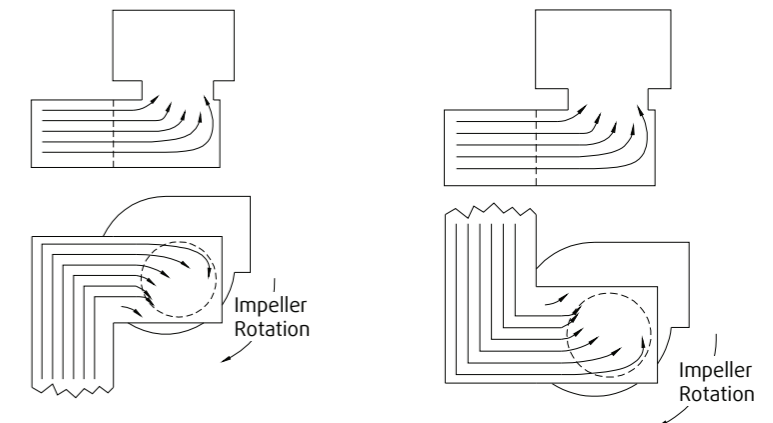

Fig. 8 Examples of duct arrangements which cause inlet swirl

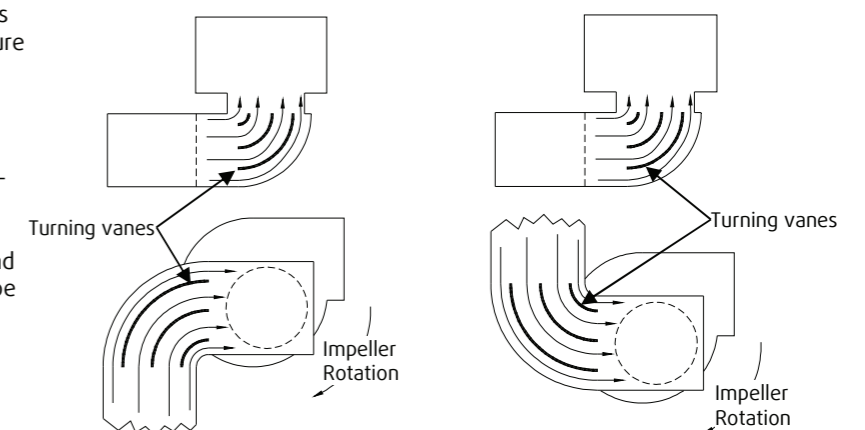

Fig. 9 Pre-swirl (left) and contra-swirl (right) corrected by use of turning vanes.

**Enclosures
(plenum and cabinet effects)**

Fans within air handling units, plenums, or next to walls should be located so that air flows unobstructed into the inlets. Performance is reduced if the distance between the fan inlet and the enclosure is too restrictive. It is usual to allow one-half of the inlet diameter between enclosure wall and the fan inlet.

Multiple D.I.D.W. fans within a common enclosure should be at least one impeller diameter apart for optimum performance. Fig. 11 shows fans located in an enclosure and lists the system effects as additional unmeasurable velocity pressure.

The way the air stream enters an enclosure relative to the fan also effects performance. Plenum or enclosure inlets of walls which are not symmetrical to the fan inlets will cause uneven flow and swirl. This must be avoided to achieve maximum performance but if not possible, inlet conditions can usually be improved with a splitter sheet to break up the swirl as illustrated.

Outlet Connections

The velocity profile at the outlet of a fan is not uniform, but is shown in Fig 13. The section of straight ducting on the fan outlet should control the diffusion of the velocity profile, making this more uniform before discharging into a plenum chamber or to the atmosphere. Alternatively, where there is a ducting system on the fan outlet, the straight ducting is necessary to minimise the effects of bends, etc.

The full effective duct length is dependent on duct velocity and may be obtained from Fig. 14. If the duct is rectangular with side dimensions a and b, the equivalent duct diameter equals

$$\sqrt{\frac{4ab}{\pi}}$$

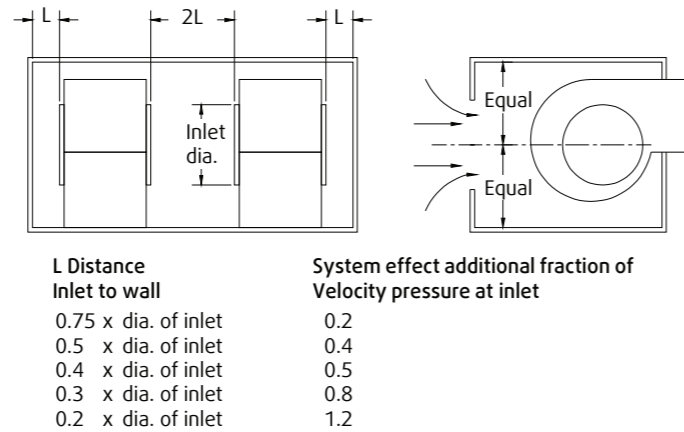

Fig. 11 System effects of fans located in common enclosure

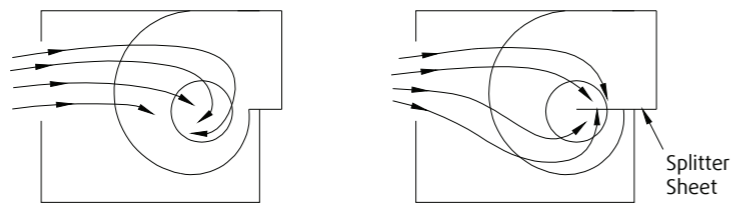

Fig. 12 Use of splitter sheet to break up swirl. Left, enclosure inlet not symmetrical with fan inlet: pre-swirl induced. Right, flow condition improved with a splitter sheet: substantial improvement would be gained by repositioning inlet symmetrically.

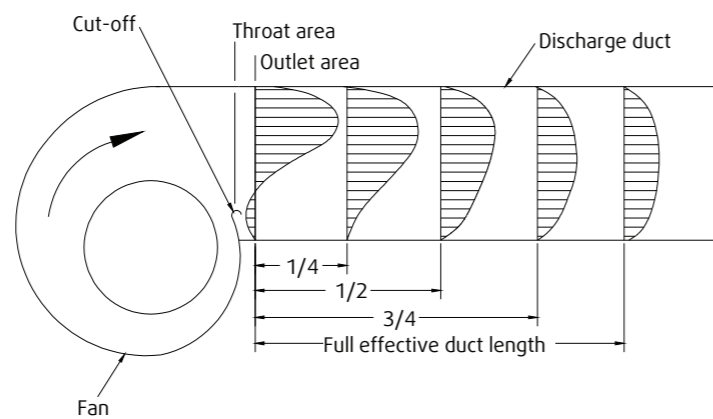

Fig. 13 Velocity profile at fan outlet (see also Fig. 14)

The use of an opposed blade damper is recommended when volume control is required at the fan outlet and there are other system components, such as coils or branch takeoffs downstream of the fan. When the fan discharges into a large plenum or to free space a parallel blade damper may be satisfactory.

For a centrifugal fan, best air performance will be achieved by installing the dampers with its blades perpendicular to the fan shaft; however, other considerations may require installation of the damper with its blades parallel to the fan shaft. Published pressure losses for control dampers are based upon uniform approach velocity profiles. When a damper is installed close to the outlet of a fan the approach velocity profile is non-uniform and much higher pressure losses through the damper can result. The multipliers in Table 3 should be applied to the damper manufacturer's catalogued pressure loss when the damper is installed at the outlet of a centrifugal fan.

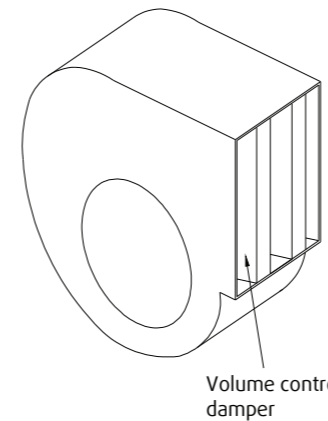

Fig. 16 Volume control damper installed at fan outlet

* The performance of volume dampers with the pressure loss multipliers are not licensed by AMCA International.

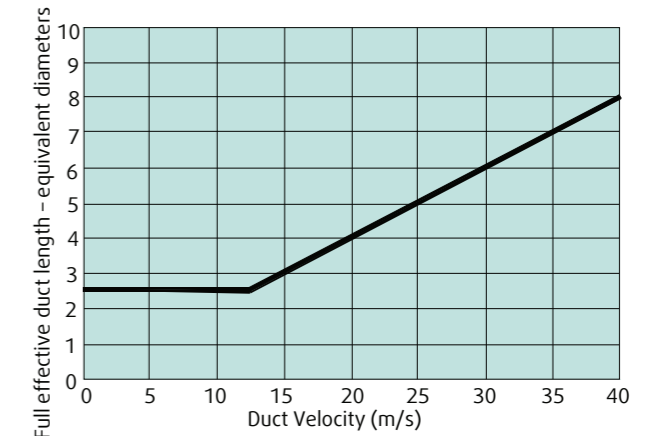

Fig. 14 Full effective duct length expressed in equivalent duct diameters

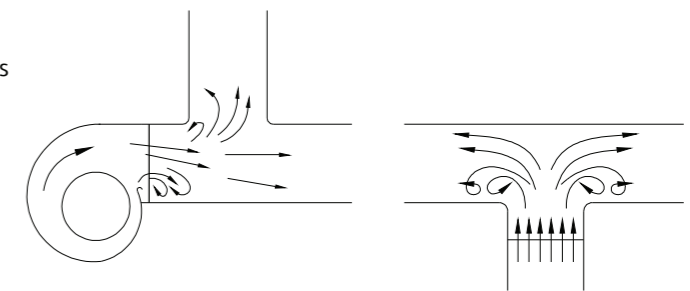

Fig.15 Branches located too close to fan. Split or duct branches should not be located close to the fan discharge: a straight section of duct will allow for air diffusion.

Throat area Outlet area	Sp multiplier
0.40	7.5
0.50	4.8
0.63	3.3
0.67	2.4
0.80	1.9
0.88	1.5
0.89	
1.00	1.5

Table 2 Pressure loss multipliers for volume control dampers

Accessories / ancillaries

In addition to the variations of diameter and impeller type, Systemair's centrifugal fans can be tailored specifically to individual needs by adding ancillary items shown in the drawing.

Customers are requested to specify at the time of ordering the ancillaries required.

Flexible Inlet Connection	Prevents transmission of vibration from fan to inlet ducting.
Flexible Outlet Connection	Prevents transmission of vibration from fan to outlet ducting.
Inlet Guard	For use when fan is not ducted on inlet
Outlet Guard	For use when fan is not ducted on outlet.
Drive Guard	Essential for proper guarding of drives.
Inspection Door	Permits examination of fan impeller for material build-up, etc.
Drain Point	Necessary where fan is handling air contaminated with liquids or vapours. The drain point is screwed to accept piping and fitted with a closing plug.
Base Frame	A rigid fabricated base which allows the fan motor and drive to be transported and installed as a complete unit. Necessary where anti-vibration mountings are required.
Anti-Vibration Mountings	Fitted to fan base to prevent transmission of vibration to adjacent structure.
Inlet / Outlet Mating Flanges	For fitting to customer's ducting or system to ensure accurate mating with fan flanges.
Spark Minimising Feature	A non-ferrous rubbing ring on inlet venturi and a non-ferrous shaft washer minimise possibility of incendiary sparks being produced. Essential where explosive or inflammable gas or vapours are being handled.
Cooling fan	Protects the fan bearings from heat conducted along shaft. Must be used for fans handling temperature above 75°C.

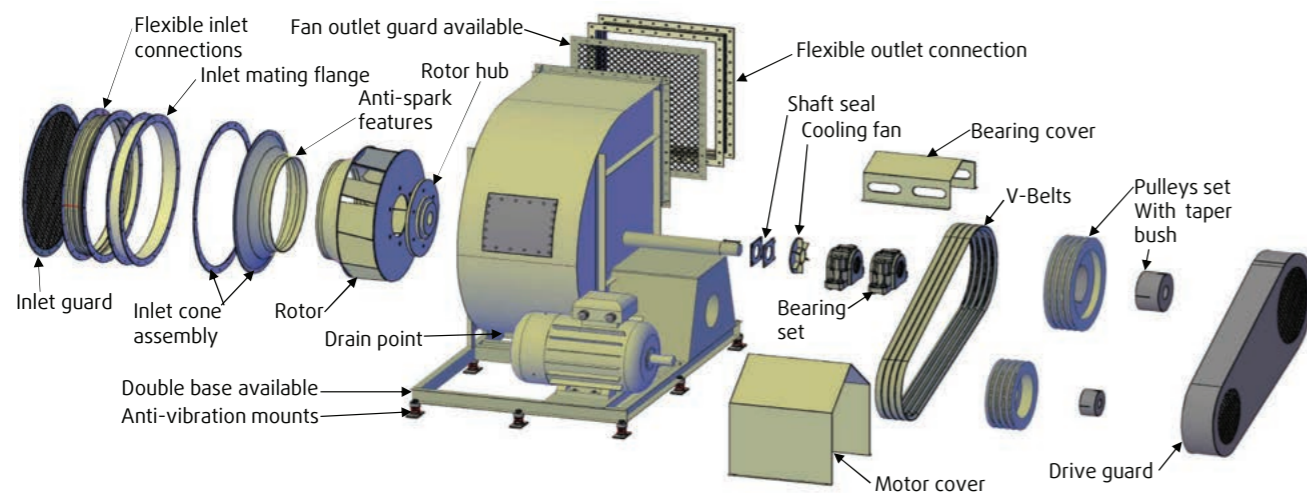

Accessories / ancillaries

Variable Inlet Vanes Provides accurate control of air volume combined with the maximum saving in power at the reduced ratings desired. The inlet vanes pre-rotate the air as it enters the fan, in effect assisting in the rotation. The vanes are constructed to provide smooth air flow into the wheel with stable volume control down to about 25% of full flow. The operating mechanism is located inside the fan and can either be manually or mechanically operated.

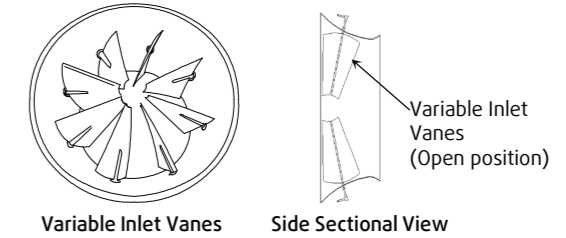

Outlet Dampers Built in a separate frame attached to the standard fan outlet. Each damper consists of a number of narrow balanced blades supported on each end by sleeve/ball bearing. Outlet dampers are low in initial cost, are simple to operate, and combine reliability of operation with reasonable efficiency when used with a fixed speed fan drive.

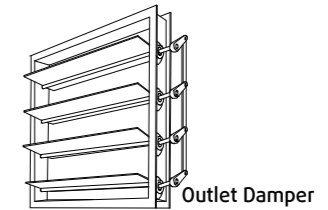

Vibration Isolators

A fan like any other rotating machine, inevitably vibrates to some extent, and is a source of vibration in the structure on which it is mounted. Unless the fan is small and light or the foundation heavy and solid it is advisable to mount the fan on vibration isolators.

By far the most common type of anti-vibration mount is the one using rubber-in-shear. Figure (a) shows typical forms that are readily available commercially. Rubber-in-shear mounts are generally acceptable for deflection of up to 12.5mm. For greater static deflection (lower natural frequencies) it will be necessary to use steel spring mounts fig. (b). These have the advantage of preserving linear stiffness and other properties over a wide range of operating conditions, and are generally unaffected by environments like wet or oily conditions. One disadvantage of a steel spring is that high frequency components of the excitation can be transmitted to the foundation by traveling along the coils of the spring itself. For this reason, a spring type isolator should always incorporate a rubber or neoprene pad between the spring and the body of the isolator. Generally, where required static deflections range from about 12.5mm up to as high as 50mm steel springs should be used.

Mats like cork, felt, or proprietary combinations of highly damped elastomers, are not generally satisfactory where good isolation is required over a wide range of frequency. Like rubber, they tend to greater stiffness under dynamic loading and their load deflection curves are not always linear. There is tendency for some materials to harden with age (thus increasing the natural frequency) and to be attacked by oil or water. Nevertheless they do have their uses, particularly in preventing the higher frequency component like electrical and bearing noises, from being transmitted. As a general rule, they should be restricted to installations where the required static deflection is less than about 6mm.

Examples of anti-vibration mount construction

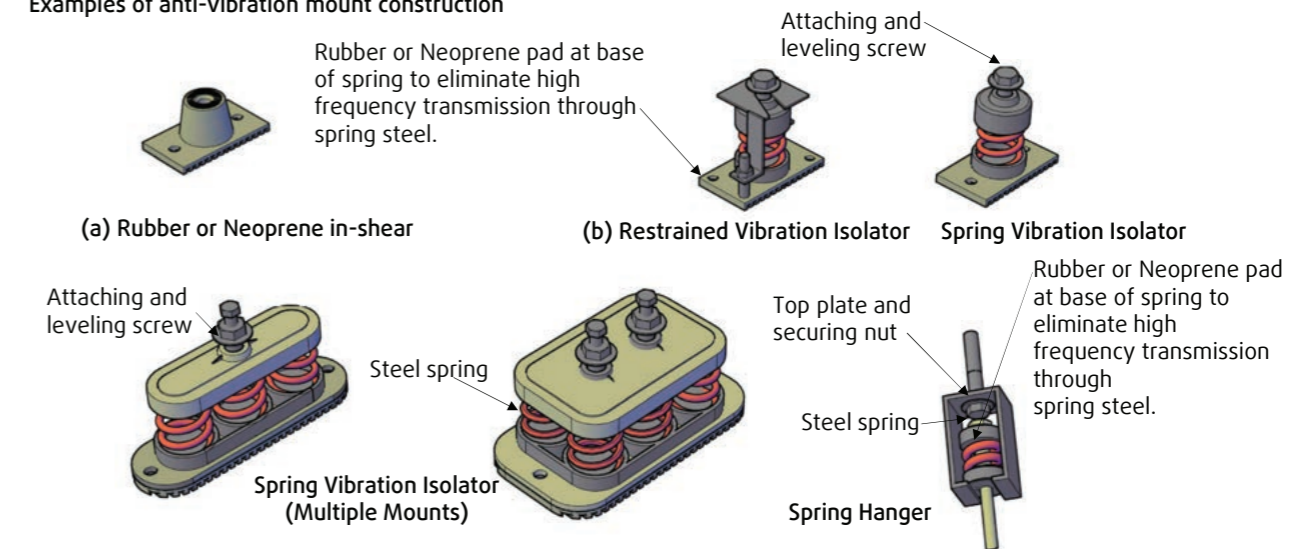

ASP 300

SWSI Centrifugal Fan

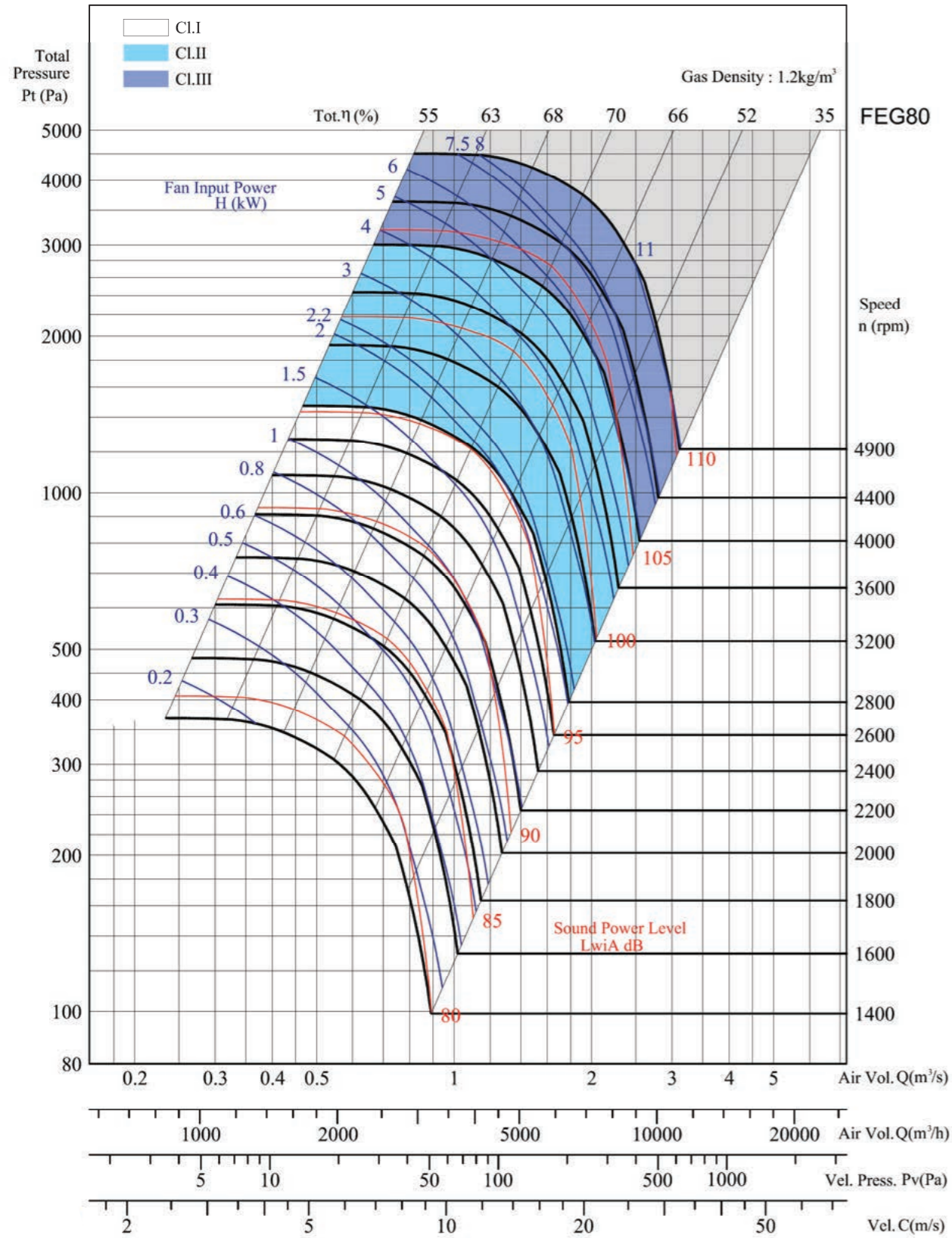

Performance certified is for installation type B – Free inlet, Ducted outlet. Power rating (kW) does not include transmission losses. Performance ratings do not include the effects of appurtenances (accessories). The A-weighted sound ratings shown have been calculated per AMCA International Standard 301. Values shown are for LwiA sound power levels for installation Type B: free inlet, ducted outlet.

ASP 350

SWSI Centrifugal Fan

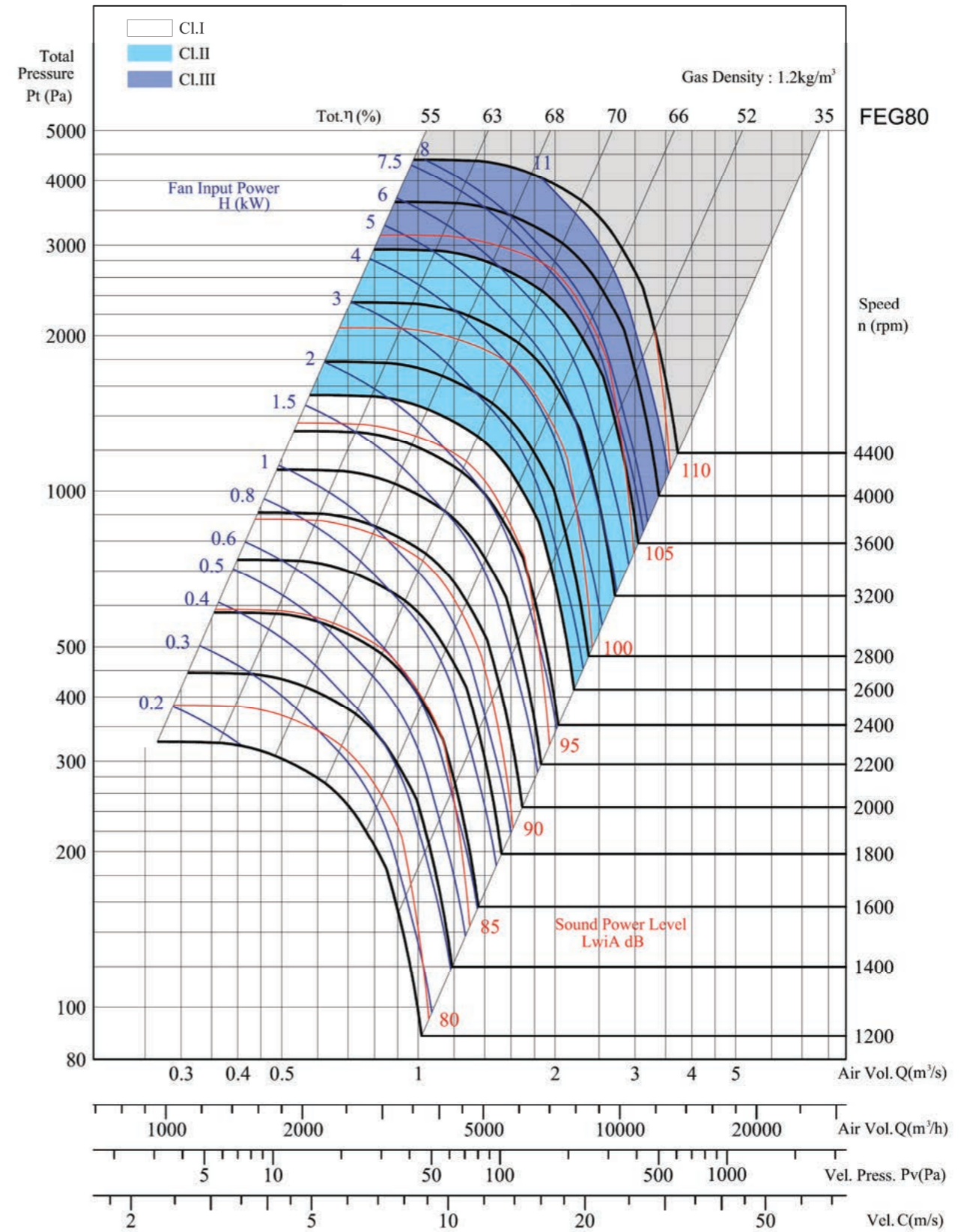

Performance certified is for installation type B – Free inlet, Ducted outlet. Power rating (kW) does not include transmission losses. Performance ratings do not include the effects of appurtenances (accessories). The A-weighted sound ratings shown have been calculated per AMCA International Standard 301. Values shown are for LwiA sound power levels for installation Type B: free inlet, ducted outlet.

ASP 400

SWSI Centrifugal Fan

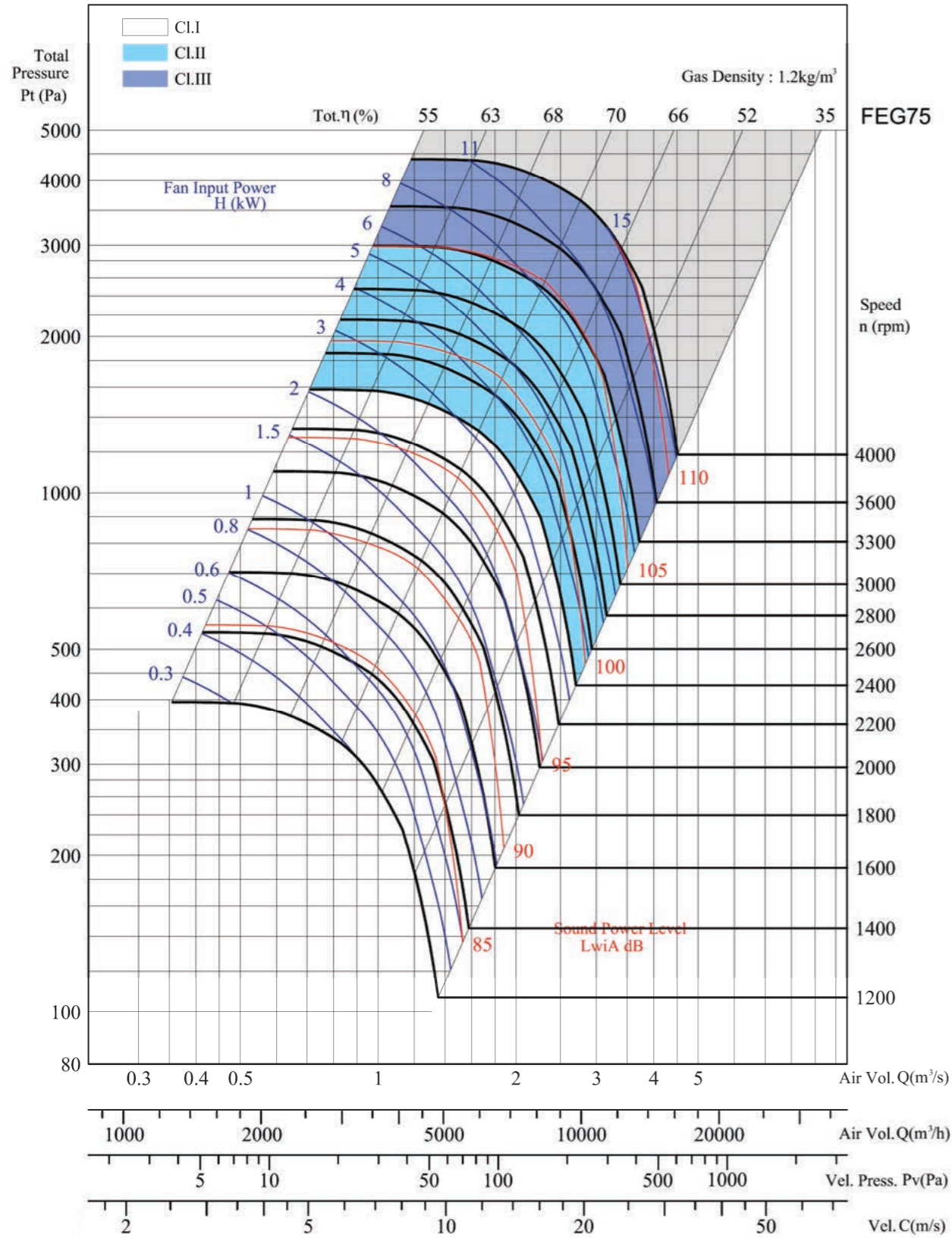

Performance certified is for installation type B - Free inlet, Ducted outlet. Power rating (kW) does not include transmission losses. Performance ratings do not include the effects of appurtenances (accessories). The A-weighted sound ratings shown have been calculated per AMCA International Standard 301. Values shown are for LwiA sound power levels for installation Type B: free inlet, ducted outlet.

ASP 450

SWSI Centrifugal Fan

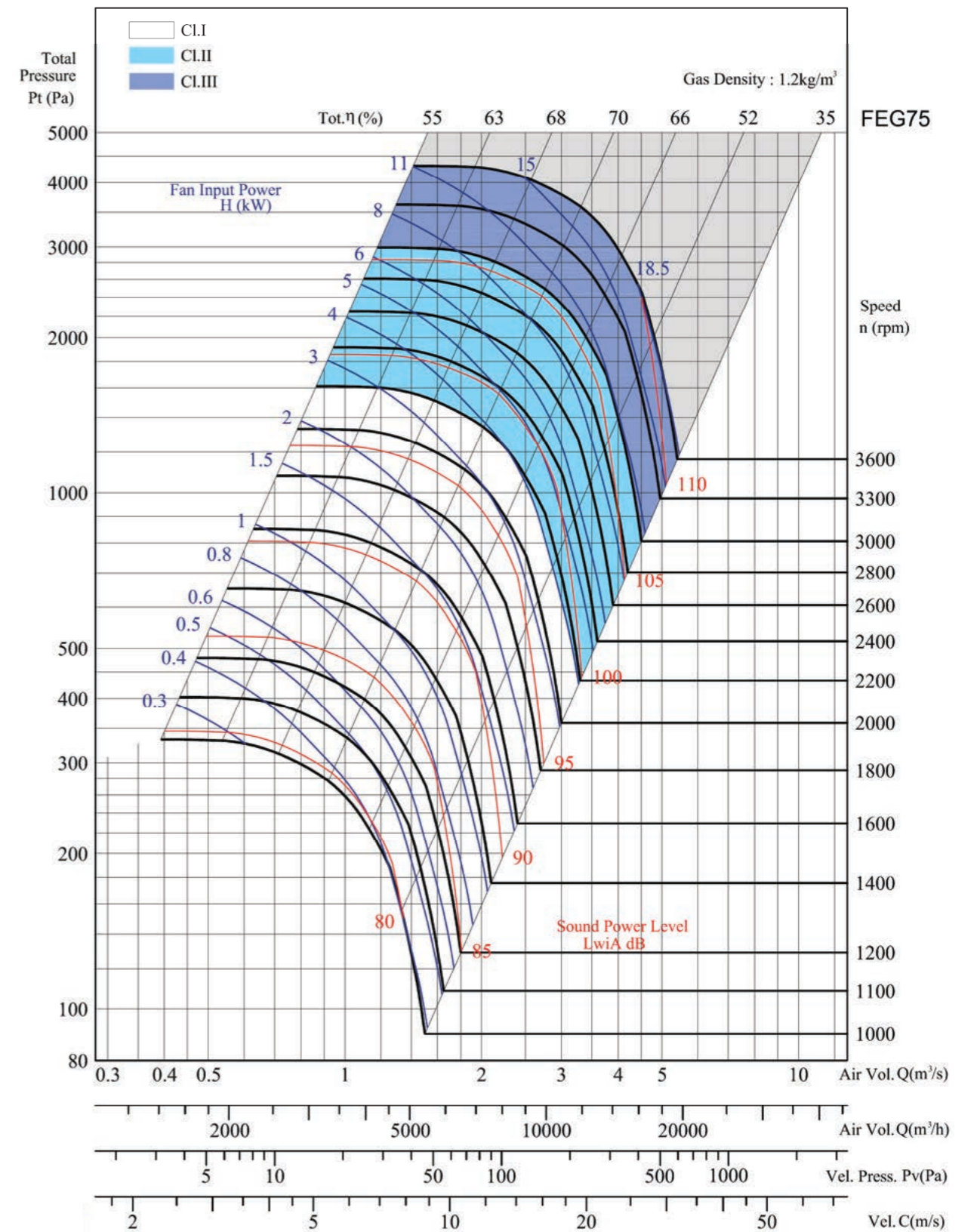

Performance certified is for installation type B - Free inlet, Ducted outlet. Power rating (kW) does not include transmission losses. Performance ratings do not include the effects of appurtenances (accessories). The A-weighted sound ratings shown have been calculated per AMCA International Standard 301. Values shown are for LwiA sound power levels for installation Type B: free inlet, ducted outlet.

ASP 500

SWSI Centrifugal Fan

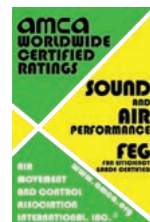
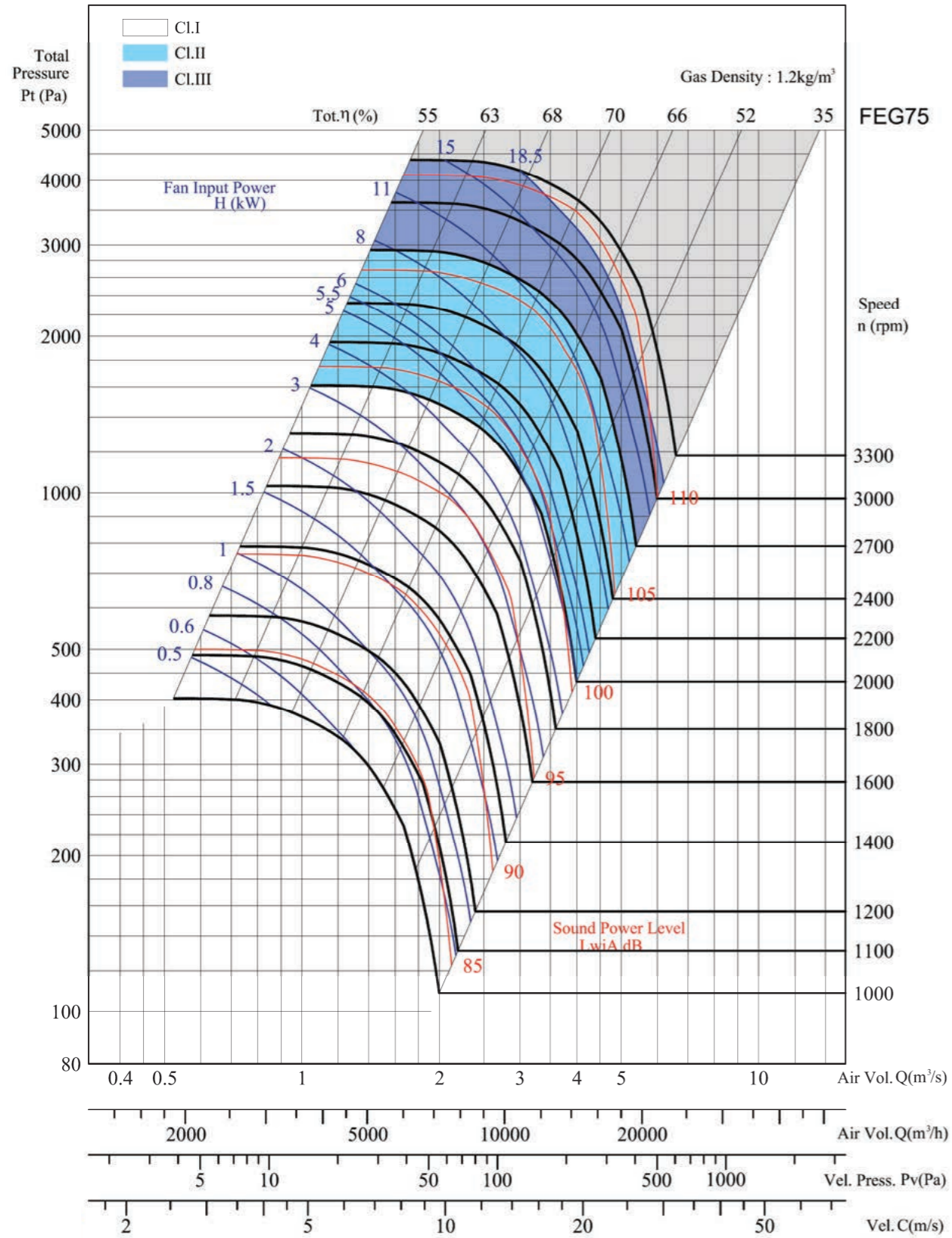

Performance certified is for installation type B - Free inlet, Ducted outlet. Power rating (kW) does not include transmission losses. Performance ratings do not include the effects of appurtenances (accessories). The A-weighted sound ratings shown have been calculated per AMCA International Standard 301. Values shown are for LwA sound power levels for installation Type B: free inlet, ducted outlet.

ASP 550

SWSI Centrifugal Fan

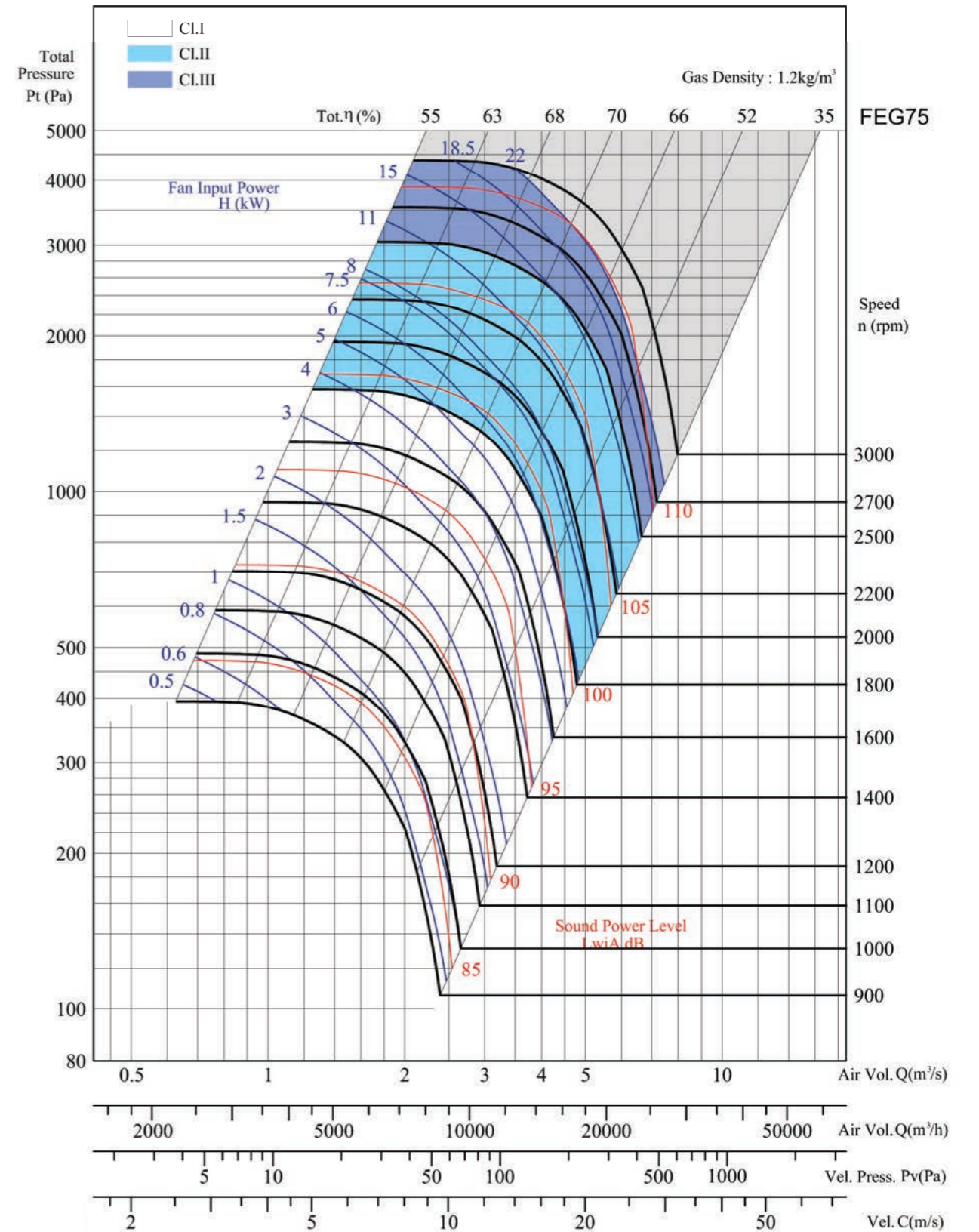

Performance certified is for installation type B - Free inlet, Ducted outlet. Power rating (kW) does not include transmission losses. Performance ratings do not include the effects of appurtenances (accessories). The A-weighted sound ratings shown have been calculated per AMCA International Standard 301. Values shown are for LwA sound power levels for installation Type B: free inlet, ducted outlet.

ASP 600

SWSI Centrifugal Fan

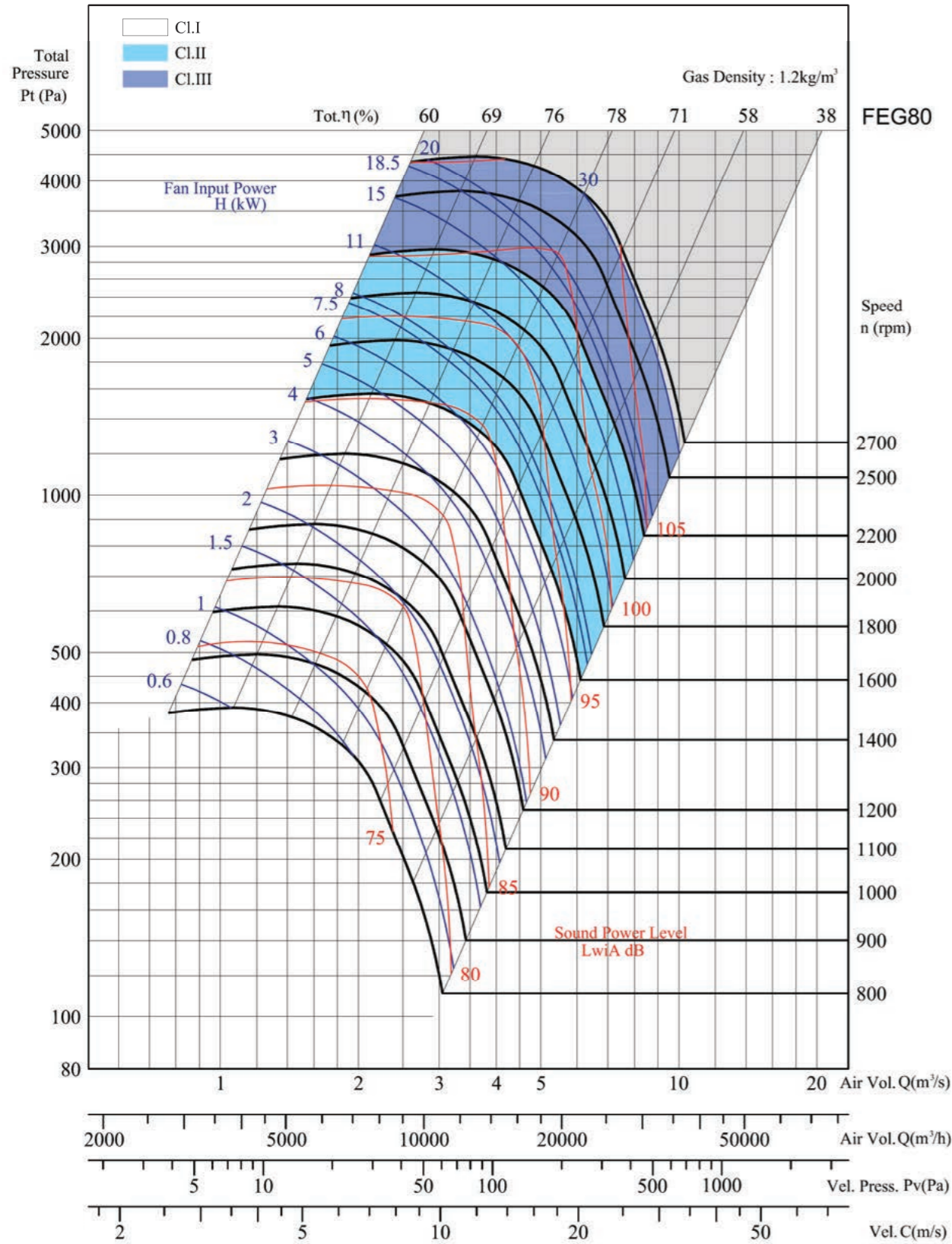

Performance certified is for installation type B - Free inlet, Ducted outlet. Power rating (kW) does not include transmission losses. Performance ratings do not include the effects of appurtenances (accessories). The A-weighted sound ratings shown have been calculated per AMCA International Standard 301. Values shown are for LwA sound power levels for installation Type B: free inlet, ducted outlet.

ASP 650

SWSI Centrifugal Fan

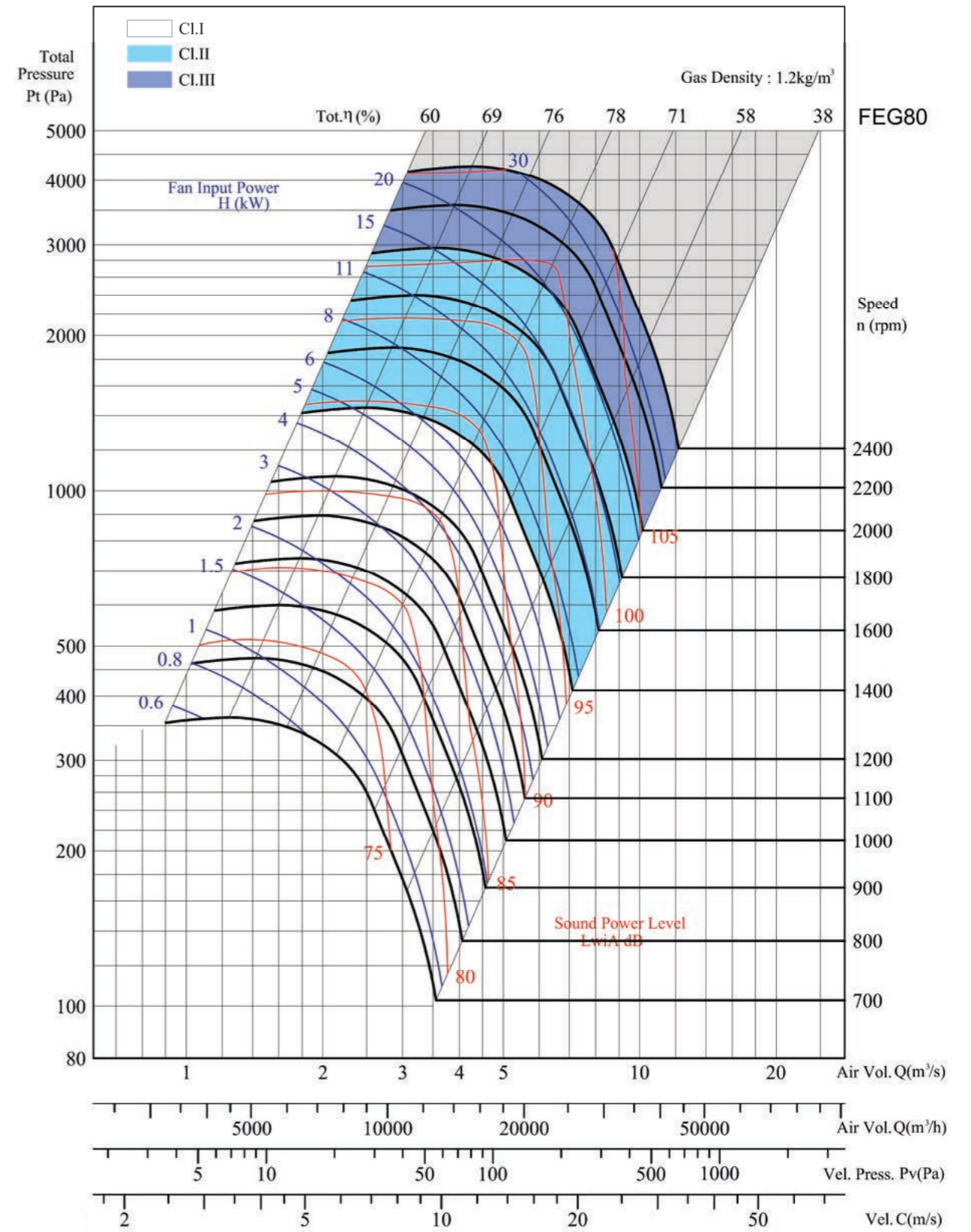

Performance certified is for installation type B - Free inlet, Ducted outlet. Power rating (kW) does not include transmission losses. Performance ratings do not include the effects of appurtenances (accessories). The A-weighted sound ratings shown have been calculated per AMCA International Standard 301. Values shown are for LwA sound power levels for installation Type B: free inlet, ducted outlet.

ASP 750

SWSI Centrifugal Fan

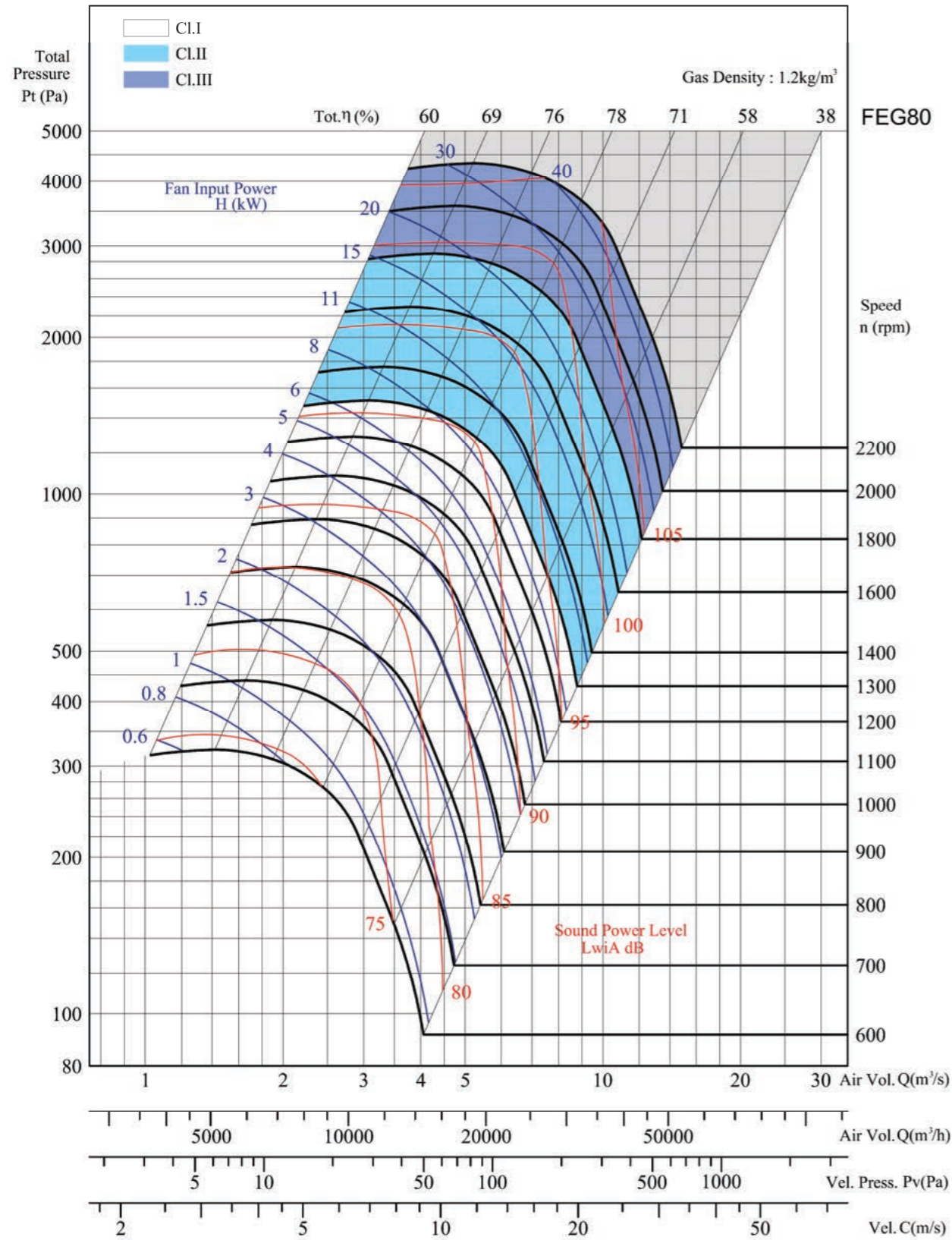

Performance certified is for installation type B - Free inlet, Ducted outlet. Power rating (kW) does not include transmission losses. Performance ratings do not include the effects of appurtenances (accessories). The A-weighted sound ratings shown have been calculated per AMCA International Standard 301. Values shown are for LwiA sound power levels for installation Type B: free inlet, ducted outlet.

ASP 800

SWSI Centrifugal Fan

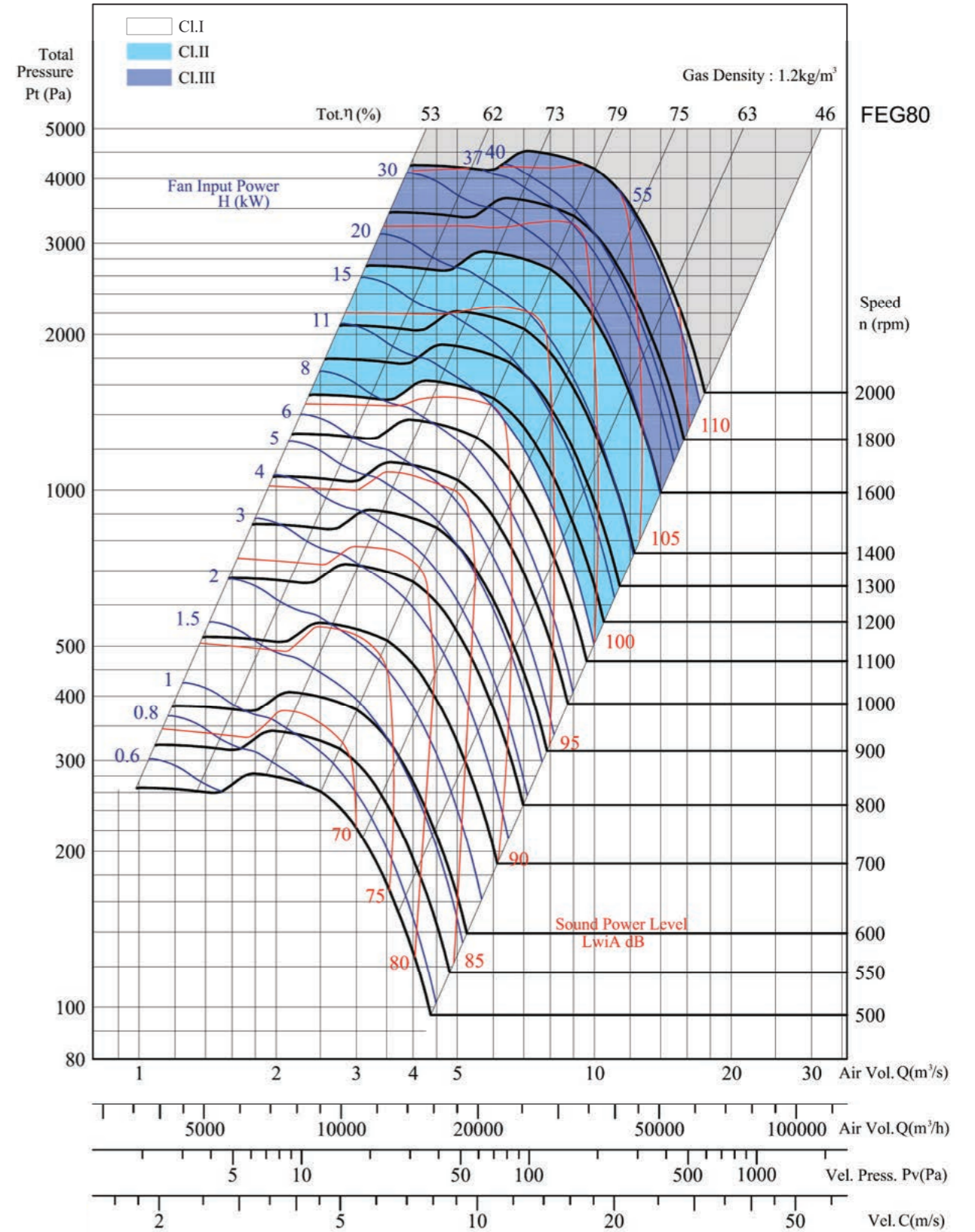

Performance certified is for installation type B - Free inlet, Ducted outlet. Power rating (kW) does not include transmission losses. Performance ratings do not include the effects of appurtenances (accessories). The A-weighted sound ratings shown have been calculated per AMCA International Standard 301. Values shown are for LwiA sound power levels for installation Type B: free inlet, ducted outlet.

ASP 900

SWSI Centrifugal Fan

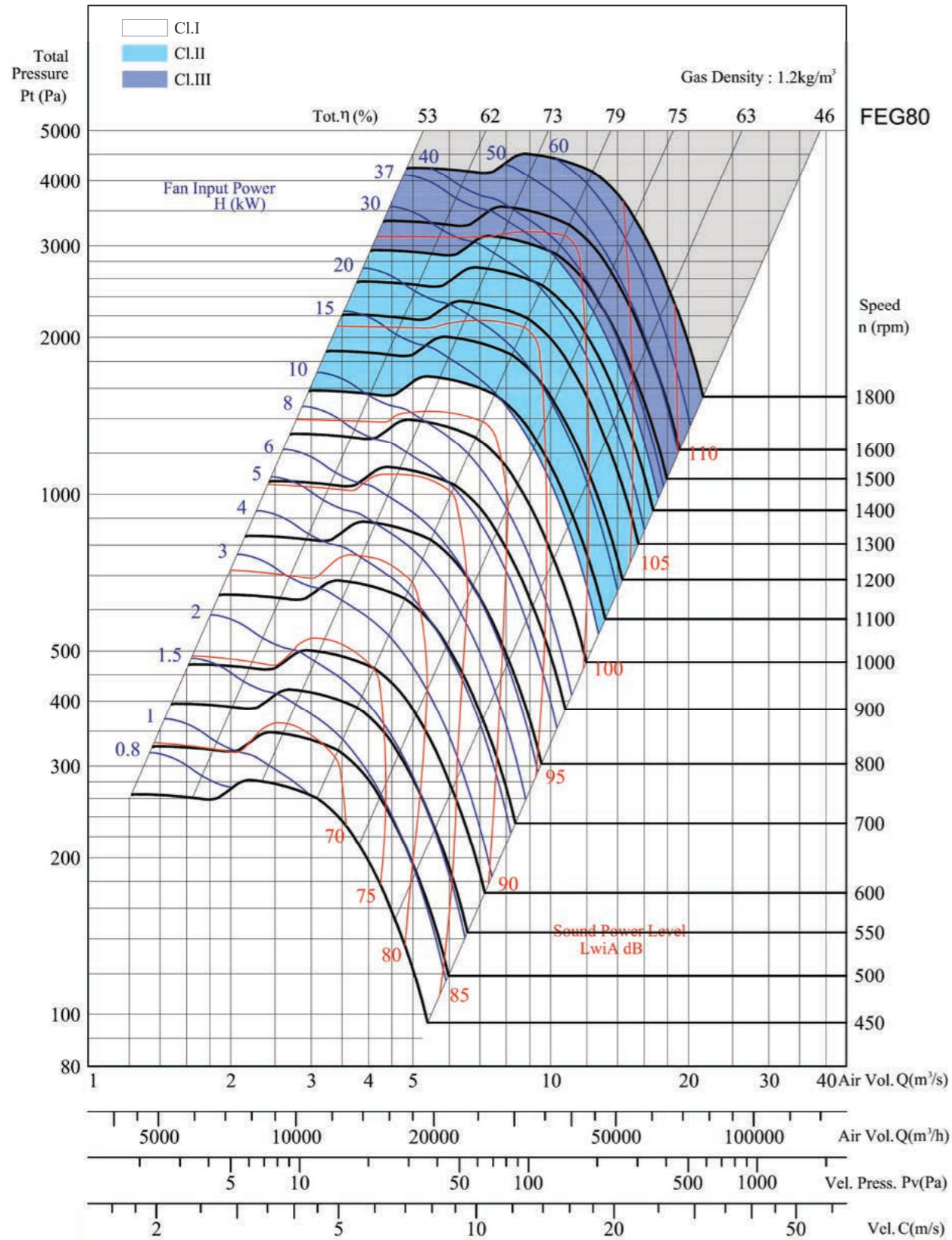

Performance certified is for installation type B - Free inlet, Ducted outlet. Power rating (kW) does not include transmission losses. Performance ratings do not include the effects of appurtenances (accessories). The A-weighted sound ratings shown have been calculated per AMCA International Standard 301. Values shown are for LwiA sound power levels for installation Type B: free inlet, ducted outlet.

ASP 1000

SWSI Centrifugal Fan

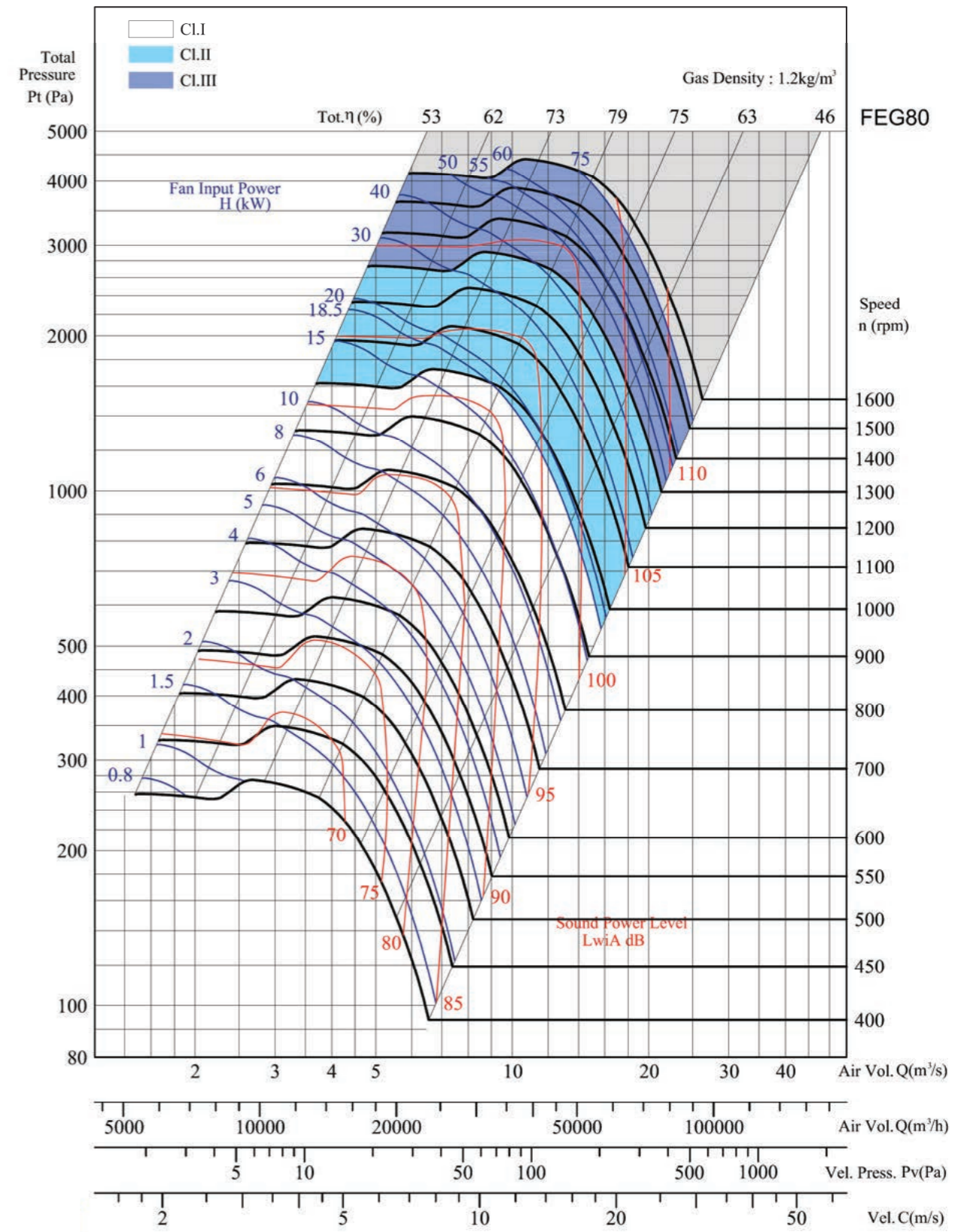

Performance certified is for installation type B - Free inlet, Ducted outlet. Power rating (kW) does not include transmission losses. Performance ratings do not include the effects of appurtenances (accessories). The A-weighted sound ratings shown have been calculated per AMCA International Standard 301. Values shown are for LwiA sound power levels for installation Type B: free inlet, ducted outlet.

ASP 1100

SWSI Centrifugal Fan

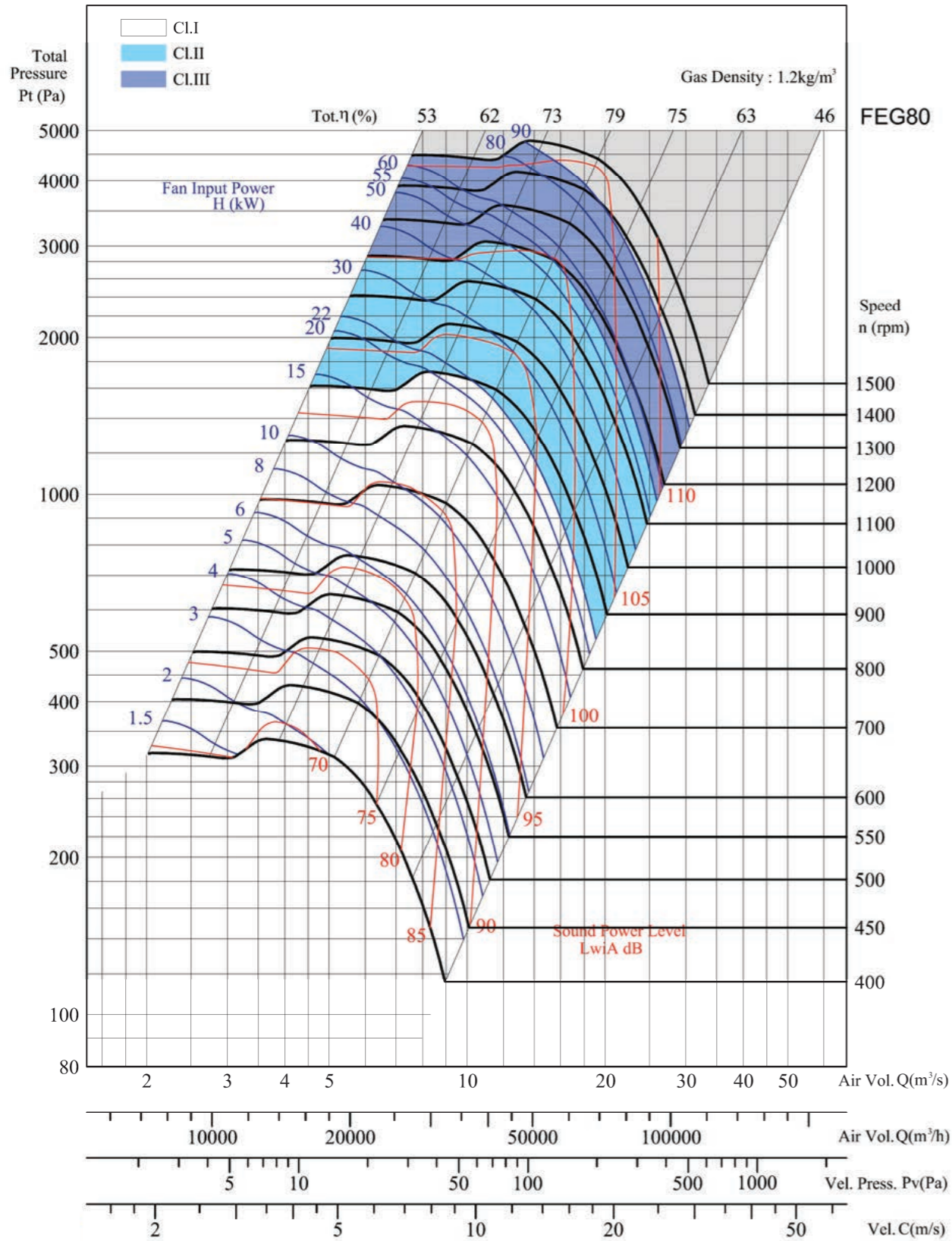

Performance certified is for installation type B - Free inlet, Ducted outlet. Power rating (kW) does not include transmission losses. Performance ratings do not include the effects of appurtenances (accessories). The A-weighted sound ratings shown have been calculated per AMCA International Standard 301. Values shown are for LwA sound power levels for installation Type B: free inlet, ducted outlet.

ASP 1200

SWSI Centrifugal Fan

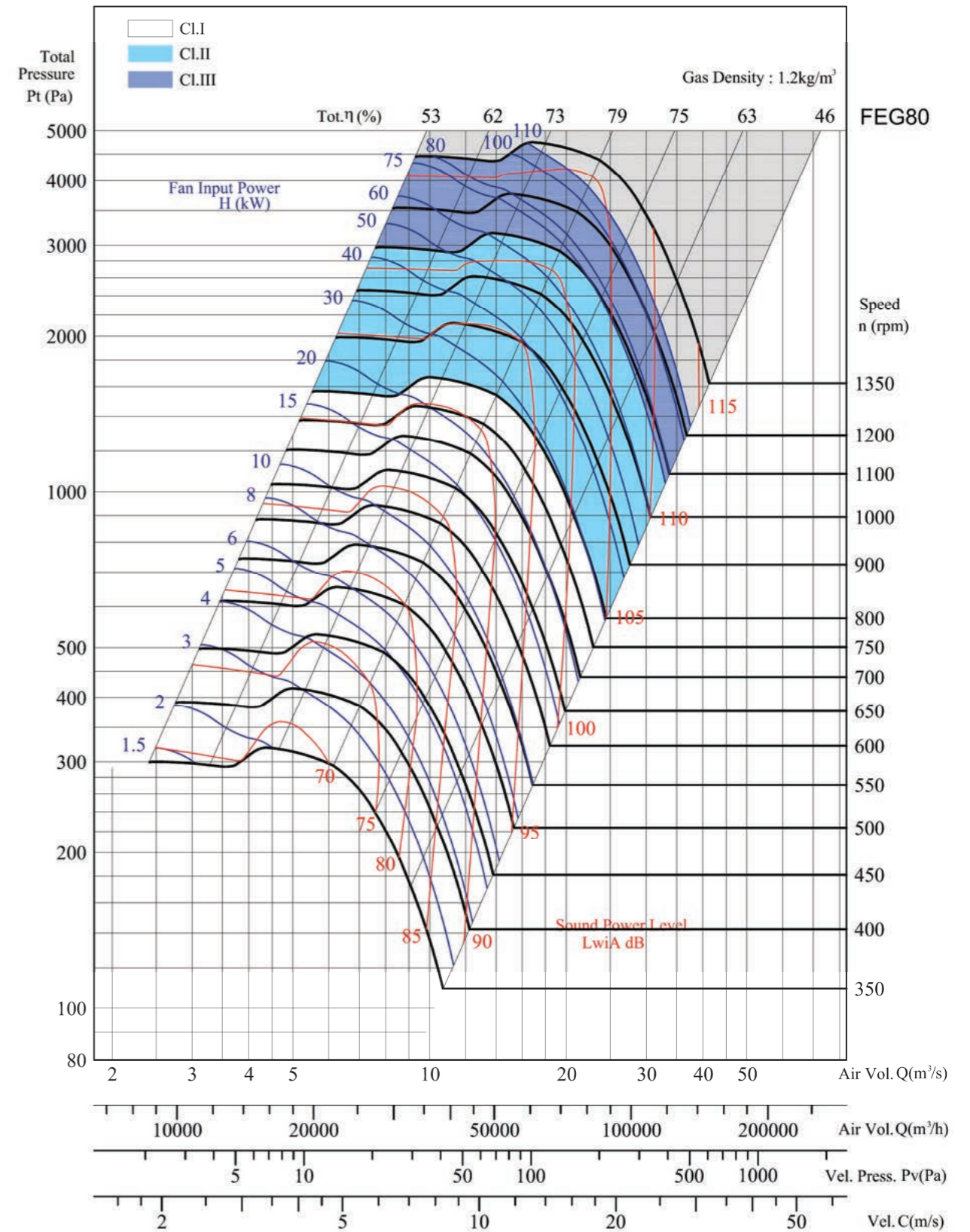

Performance certified is for installation type B - Free inlet, Ducted outlet. Power rating (kW) does not include transmission losses. Performance ratings do not include the effects of appurtenances (accessories). The A-weighted sound ratings shown have been calculated per AMCA International Standard 301. Values shown are for LwA sound power levels for installation Type B: free inlet, ducted outlet.

ASP 1350

SWSI Centrifugal Fan

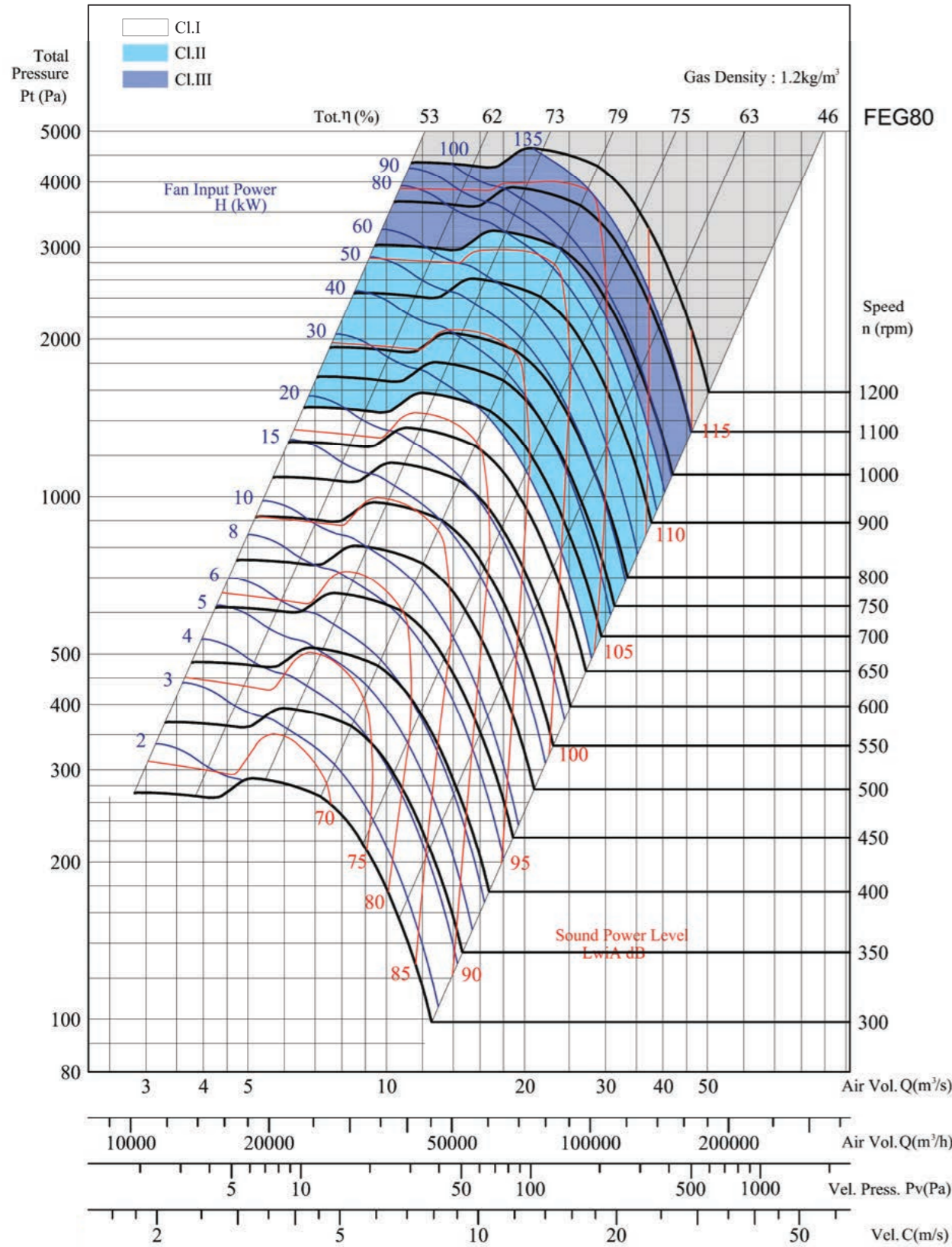

Performance certified is for installation type B - Free inlet, Ducted outlet. Power rating (kW) does not include transmission losses. Performance ratings do not include the effects of appurtenances (accessories). The A-weighted sound ratings shown have been calculated per AMCA International Standard 301. Values shown are for LwA sound power levels for installation Type B: free inlet, ducted outlet.

ASP 1450

SWSI Centrifugal Fan

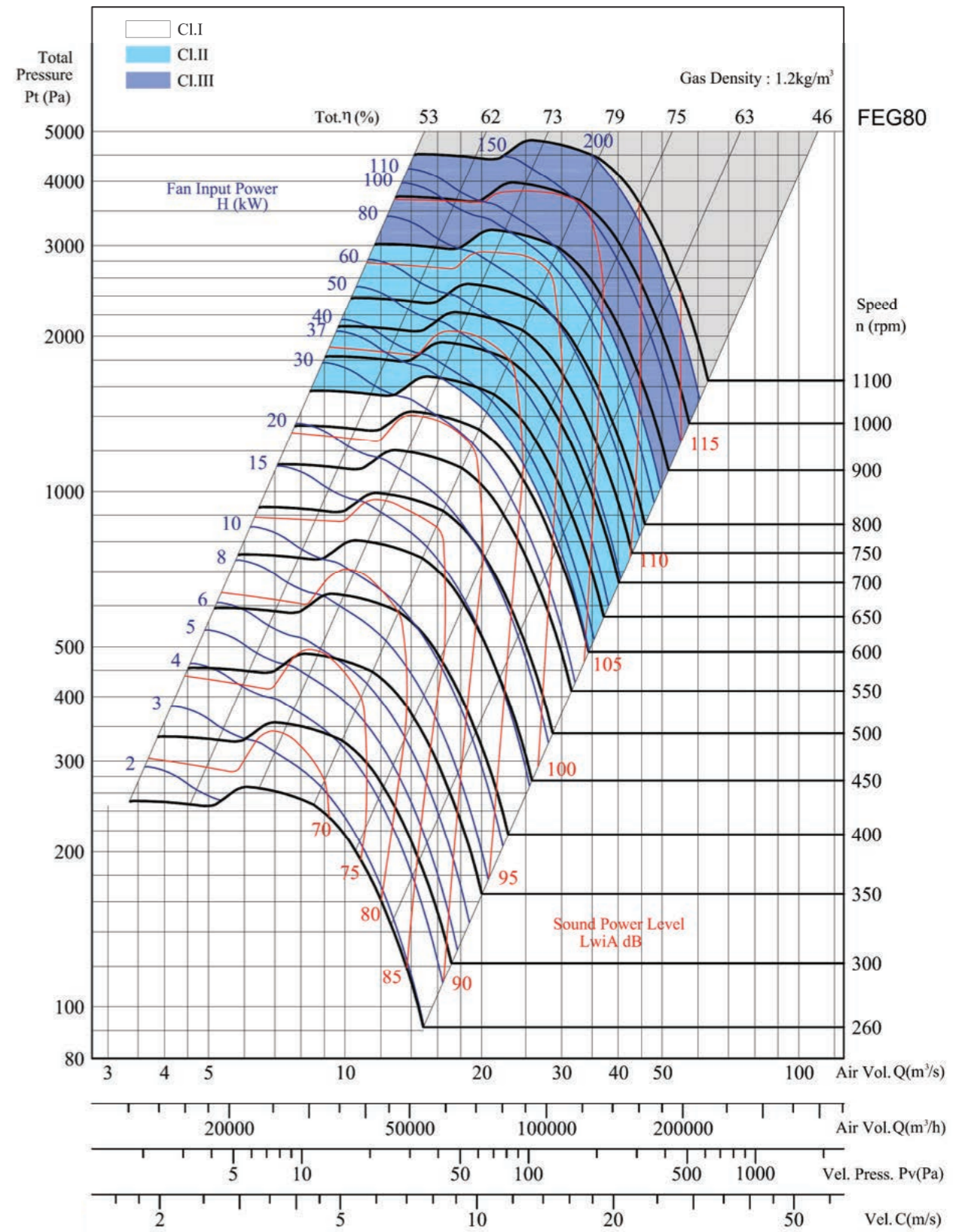

Performance certified is for installation type B - Free inlet, Ducted outlet. Power rating (kW) does not include transmission losses. Performance ratings do not include the effects of appurtenances (accessories). The A-weighted sound ratings shown have been calculated per AMCA International Standard 301. Values shown are for LwA sound power levels for installation Type B: free inlet, ducted outlet.

ASP 1650

SWSI Centrifugal Fan

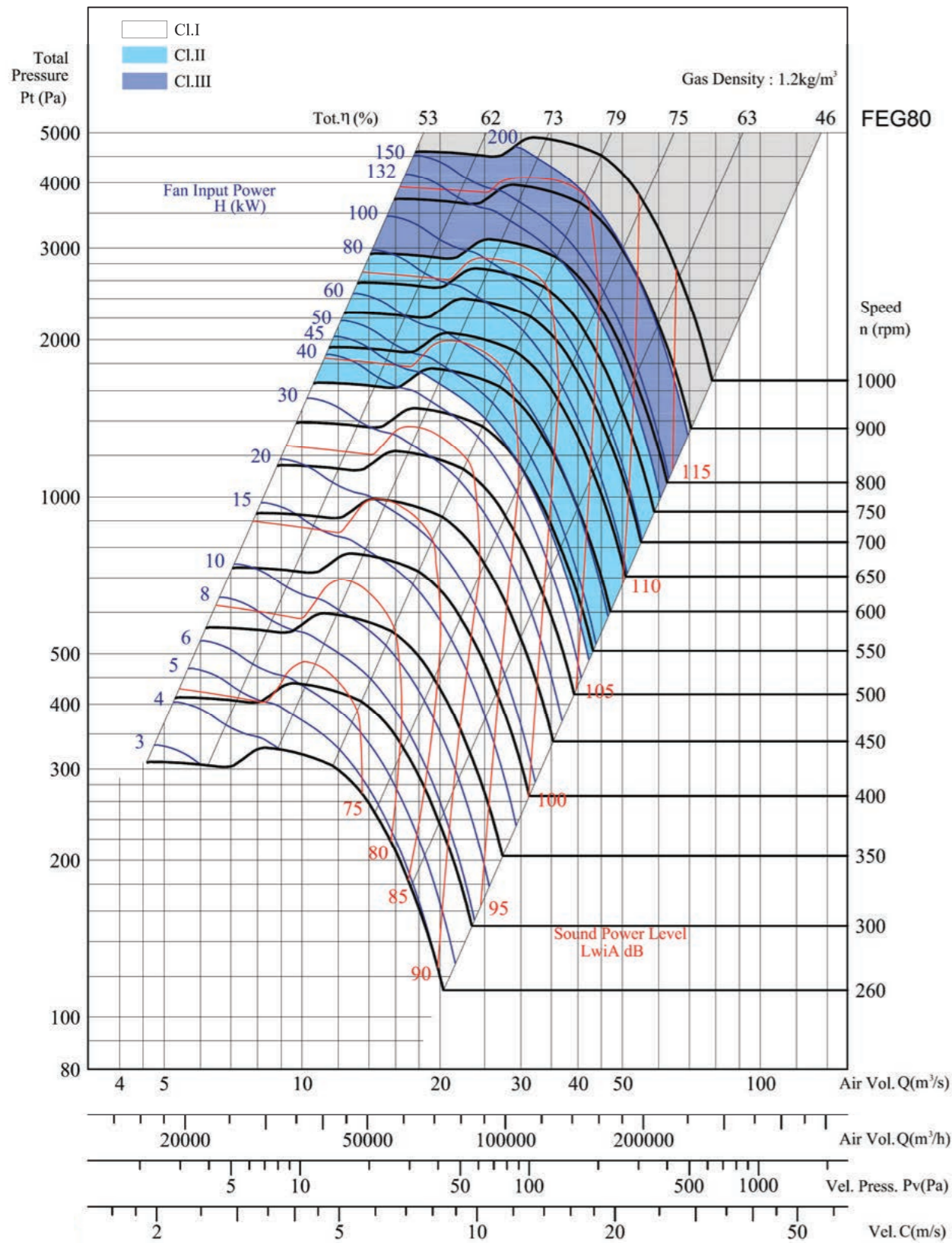

FEG80

Fan arrangements and dimensions

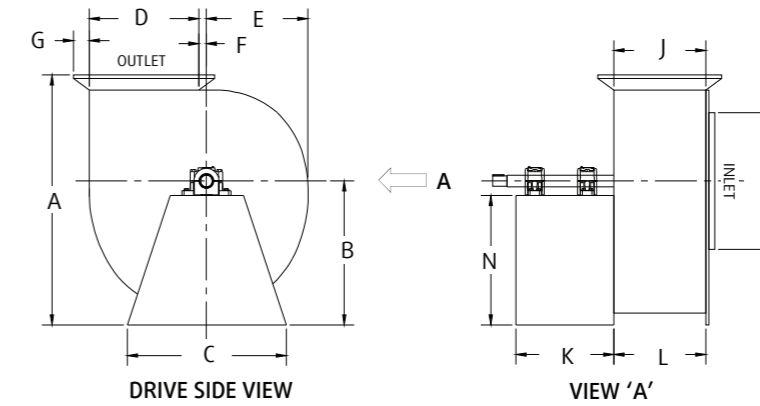
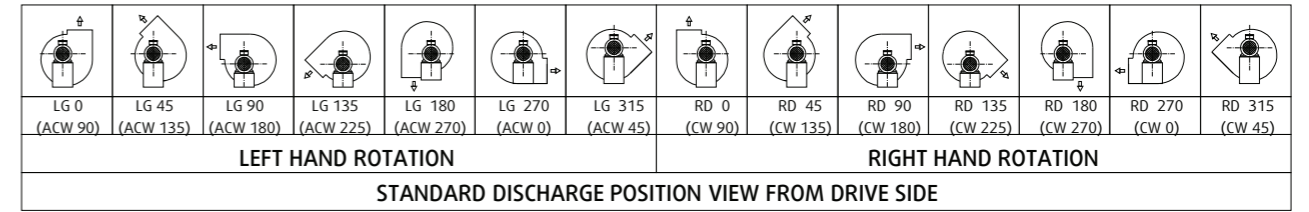

ASP SWSI dimensions

Fan size	300	350	400	450	500	550	600	650	750	800	900	1000	1100	1200	1350	1450	1650
A	627	684	746	815	903	986	1088	1189	1300	1422	1556	1726	1889	2080	2277	2493	2730
B	341	373	409	447	490	537	589	656	718	787	863	956	1048	1148	1260	1381	1515
C	445	485	510	535	580	610	635	660	690	780	880	1020	1060	1120	1320	1370	1425
D	308	339	373	410	451	496	546	600	660	726	799	879	967	1063	1170	1287	1415
E	271	298	328	361	397	437	480	529	581	640	704	774	851	937	1030	1133	1247
F	26	29	32	35	38	42	47	51	56	62	68	75	83	91	100	110	121
G	38	38	38	38	50	50	50	50	50	50	50	63	63	76	76	76	76
H	361	397	436	480	528	581	639	703	773	850	935	1029	1132	1245	1369	1506	1657
J	270	299	333	367	404	440	495	545	597	663	730	807	809	981	1090	1213	1335
K	290	300	310	325	350	400	430	430	430	485	485	635	660	710	810	830	915
L	270	299	333	367	404	440	495	545	597	663	730	807	890	981	1090	1213	1335
N	296.5	325	385.5	398	439	478	535	593	655	694	797	873	975	1110	1186	1295	1456.5



Performance certified is for installation type B - Free inlet, Ducted outlet. Power rating (kW) does not include transmission losses. Performance ratings do not include the effects of appurtenances (accessories). The A-weighted sound ratings shown have been calculated per AMCA International Standard 301. Values shown are for LwA sound power levels for installation Type B: free inlet, ducted outlet.

Fan weights

Fan weights do not include motor, drive, guards, springs or bases								
SWSI								
Class 1					Class 2			
Arrangement								
Fan size	1	2	3	4	1	2	3	4
SPB 300	80	68	65	75	86	72	77	82
SPB 350	98	86	82	93	104	98	90	101
SPB 400	112	93	91	98	119	98	103	109
SPB 450	135	100	95	116	140	105	120	128
SPB 500	154	121	114	144	164	128	151	158
SPB 550	170	147	142	158	181	155	168	172
SPB 600	195	172	168	191	204	180	195	213
SPB 650	270	228	205	242	291	235	265	255
SPB 750	316	256	240	340	336	267	310	354
SPB 800	382	316	314	414	405	348	382	430
SPB 900	486	412	386	488	514	426	435	502
SPB 1000	698	559	468		742	568	582	
SPB 1100	802	682	596		854	715	750	
SPB 1200	966	811	875		1034	848	936	
SPB 1350	1235	1037	1052		1320	1101	1112	
SPB 1450	1492		1286		1637	1392		
SPB 1650	1819		1426		2091	1684		

Weight in KG

Metric and imperial conversion factors

Quantity	Imperial Unit	SI Unit	Conversion Factor
Volume flowrate	cfm (ft ³ /min)	cubic metres per second (m ³ /s)	4.7195 x 10 ⁻⁴
	cfm (ft ³ /min)	litres per second (l/s)	4.7195 x 10 ⁻¹
	cu sec (ft ³ /sec)	cubic metres per second (m ³ /s)	2.8316 x 10 ⁻²
Pressure	inches w.g.	pascal (Pa or N/m ²)	2.4909 x 10 ²
	inches w.g.	kilopascal (kPa)	2.4909 x 10 ⁻¹
	inches w.g.	millibar (mbar)	2.4909
	inches hg.	kilopascal (kPa)	3.3864
Power	hp (bhp or ahp)	watt (W or J/s)	7.4570 x 10 ²
	hp	kilowatt (kW)	7.4570 x 10 ⁻¹
Torque (5)	lbf-in	newton metre (Nm)	1.1298 x 10 ⁻¹
	lbf-ft	newton metre (Nm)	1.3558
Density	lb/ft ³	kilogramme per cubic metre / (kg.m ³)	1.6018 x 10
Tip speed	fpm (ft/min)	metres per second (m/s)	5.0800 x 10 ⁻³
Outlet velocity or Duct velocity	fps (ft/sec)	metres per second (m/s)	3.0480 x 10 ⁻¹
	mph (miles/hr)	metres per second (m/s)	4.4704 x 10 ⁻¹
Rotational speed (2)	rpm (rev/min)	revolutions per second (rev/s)	1.6667 x 10 ⁻²
Dimensions	inches	millimeters (mm)	2.5400 x 10
	feet	metre (m)	3.0480 x 10 ⁻¹
	thou (mil) = .001 in	micrometre (µm)	2.5400 x 10
Moment of inertia (6)	lb-ft ²	kilogramme metre squared (kg m ²)	4.2140 x 10 ⁻²
	slug-ft ²	kilogramme metre squared (kg m ²)	1.3558
Stress (5)	lbf-in ²	pascals (Pa or N/m ²)	6.8948 x 10 ³
	ton f-in ²	megapascal (Mpa)	1.5444 x 10
Energy (work or heat equivalent)	Therm	megajoule (MJ)	1.0551 x 10 ⁻²
	hp hr (horse power hour)	megajoule (MJ)	2.6845
	Btu (British thermal unit)	kilojoule (kJ)	1.0551
	Ft-lbf	joule (J)	1.3558
Temperature (3)	kW hr	megajoule (MJ)	3.6000
	°F	kelvin	(°F + 459.67) ÷ 1.8

The recognised units now are those in the 'Système International' (SI), a logical modification of the earlier metric system.

Given above are number of conversion factors designed to assist those who are unfamiliar with the magnitude of the SI units. They will also be useful in converting from earlier textbooks, catalogues, and other data.

Note

1.) The choice of the appropriate multiple or sub-multiple of an SI unit is governed by convenience. The multiple chosen for a particular application should be the one which will lead to numerical values within a practical range (i.e. kilopascal for pressure, kilowatts for power and megapascal for stress).

2.) The second is the SI base unit of time, although outside SI the minute has been recognised by CIPM as necessary to retain for use because of its practical importance. We have therefore continued the use of rev/min for rotational speed.

3.) The kelvin is the SI base unit of thermodynamic temperature and is preferred for most scientific and technological purposes. The degree celcius (°C) is acceptable for practical applications.

4.) Multiply Imperial unit by this factor to obtain SI Standard, except the kelvin temperature.

5.) Great care must be taken in the conversion of these units. In the imperial system the pound force or weight lbf (mass x acceleration due to gravity) was often loosely referred to as 'lb'.

6.) For reasons as in (5) above inertia

was given as $\frac{W}{g} \text{ k}^2$ i.e. slug/ft²

Multiplies

Name	Symbol	Factor
micro	µ	10 ⁻⁶
milli	m	10 ⁻³
kilo	k	10 ³
mega	M	10 ⁶

Examples

- a 5712 c.f.m. = 5712 x 4.7195 x 10⁻⁴
= 2.6958 m³/s
- b 20.6 c.f.m. = 20.6 x 4.7198 x 10⁻¹
= 9.7228 l/s
- c 1.35 in. w.g. = 1.35 x 2.4909 x 10²
= 336.27 Pa
- d 40.6 in w.g. = 40.6 x 2.4909 x 10⁻¹
= 10.11 kPa

and so on.

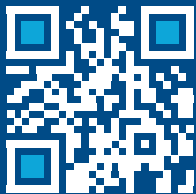

Comprehensive information for selecting the most suitable fan for your application is available via our fansSelect selection software.

www.pacificventilation.com/downloads



We are the safe choice.



PV00146_JAN_2021_Version 1.0.0



Pacific Ventilation

Pacific Ventilation Pty Ltd

AU 1300 733 833

NZ 0800 100 326

sales@pacificventilation.com

www.pacificventilation.com