

# Intelligent Ventilation

Systemair car park solution for multi-storey and underground car parks



# One System. Many advantages.

## Local technical support nationwide

- Our experts offer advice and consultation to help you reach the best solution for your needs

## Pre-programmed car park controller

- Dual bus system allows for sensors and Jetfans to communicate with the controller independently
- Dual-bus Modbus Communication – ease of diagnosing modbus devices
  - 1x Modbus communication bus for CO Sensors
  - 1x Modbus communication bus for Jet fans
  - 2x Analogue control for supply and extract fans
- Fire shutdown with manual override control for system
- Access to ebm-papst EC motor electronics for fault finding and addressing
- Controller will undertake sleep mode under 9ppm< according to AS1668-2012-4.11
- Between 9-35ppm – proportional control to maintain CO levels

## Computational fluid dynamics (CFD modelling)

- In-house CFD modelling by experienced engineers
- Ease of communication – variations vs revisions
- Precision positioning of Jet fans for optimum carbon monoxide levels

## Jet fans EC

- ebm-papst advanced electronics motor
- Modbus address can be programmed by the controller
- All settings and motor running time is accessible via the controller
- Slim modern design for maximum aerodynamic performance
- Available in 50N and 90N thrust models

## Extract/Supply Fans

- Inline Axial EC
- Inline Axial AC plus VSD
- Wall mounted plate EC
- Inline centrifugal EC
- Roof mounted Axial EC

## Carbon monoxide sensor

- Real time detection and to transmit ambient carbon monoxide levels
- Up to 5 years of lifetime
- Modbus communication interface
- Environmentally friendly Electro-Chemical sensor

# Car park design by CFD

The all-inclusive design package from Systemair. Based on CFD modelling according to AS1668.2

Whether planning, implementing, commissioning or acceptance – in complex projects, each phase presents a real challenge to you and your team. Especially when ventilation and electrical plant – with their different requirements – come up against each other. We at Systemair want to make your daily work as easy as possible and offer you the greatest possible levels of safety.

This is why we will support you with a lot of expertise, high-performance products and as much service as you wish. You could even go for our all inclusive service package: from conception and detailed planning through to the final report. This means we have an overview of all the planning phases and building services, coordinate the interfaces and are able to support you in the best possible way.

## CFD simulation

We can simulate the air flows within your underground car park using CFD simulation (Computational Fluid Dynamics). This means we are already able to check in the planning phase, whether the air motion is sufficient for the required optimum CO level and if enough jet fans have been planned in. The installation positions of the jet fans will also be determined. All we need for this is a 3D model of your building which includes all the flow-relevant information, such as all the openings, the ceiling heights and the nature of the ceilings (flat, with beams etc.).

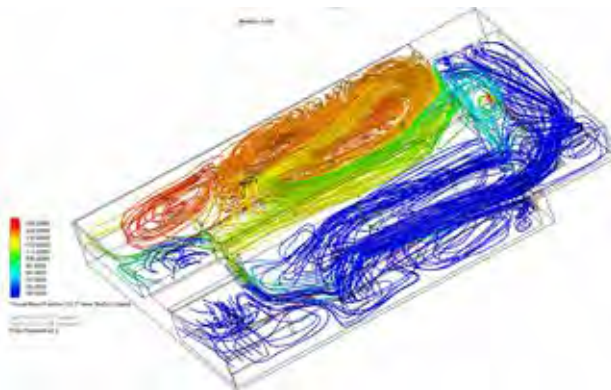

CO levels flow Trajectories using 3x JVC25

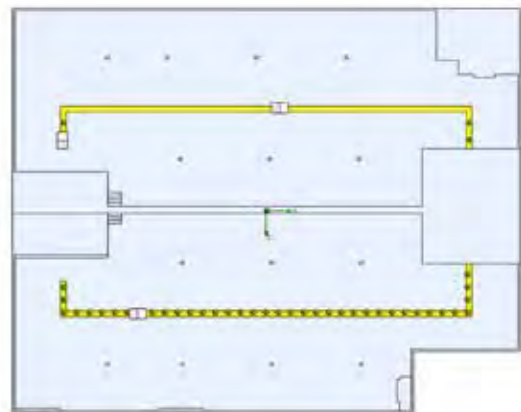

Car park Jet fans positioning

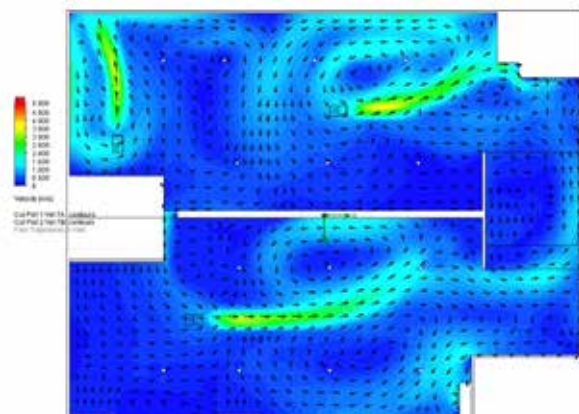

Velocity 1.6m AFL

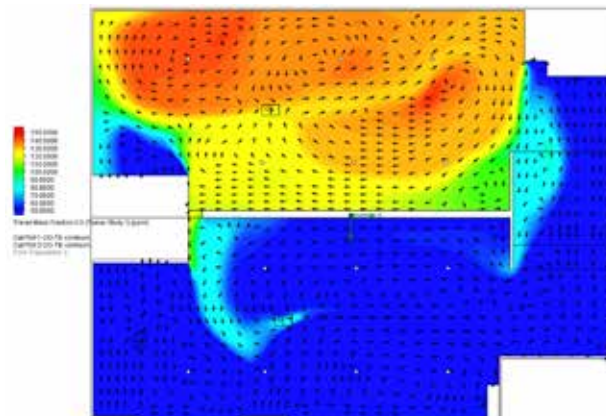

CO levels 1.6m AFL

# Jet Fan

The JVC is an advanced EC jet impulse fan based on the technically superior ebm-papst RadiCal backward curved centrifugal impeller. The centrifugal wheel design delivers exceptional air efficiency. The low profile design is advantageous where head clearances are restricted.

The fans incorporate high-efficiency permanent magnet EC motors with on-board speed control and intelligent interface capability with BMS. Jet fans are factory enabled to operate 100% in case of any fault. Cases are formed from corrosion-resistant powder coated galvanized sheet steel. C5 Rated according to ISO 12499.

## Dimensions

Fan	A	B	C	D	E	F	G
JVC25	1070	1445	900	990	400	600	343
JVC50	1270	1744	1103	1190	450	600	440

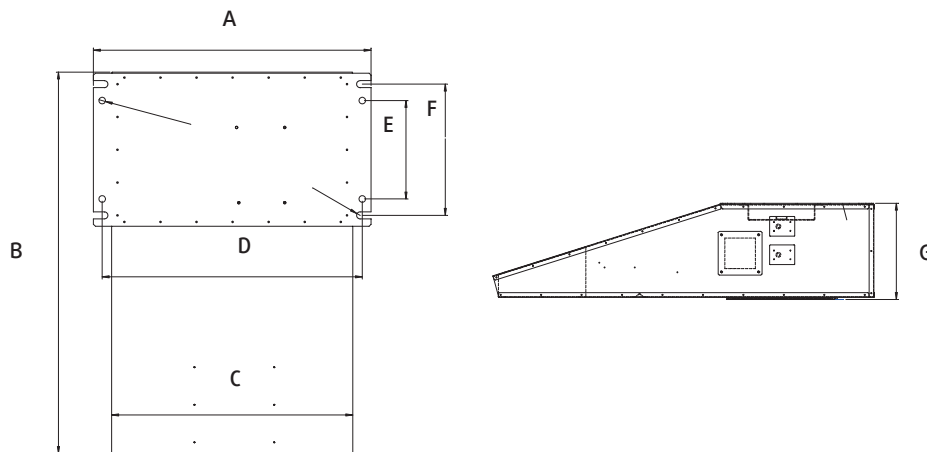

## Performance

Fan model	Nominal Thrust N	Motor kW	Motor Amps	Air Speed m/s	Airflow m <sup>3</sup> /hr	Max RPM	Weight kg	SPL dB(A) @ 3m
JVC25	50	0.97	1.7	25	5800	1550	85	52
JVC50	90	2.90	4.43	28	11,000	1750	155	55

## Quality

Pacific Ventilation is ISO 9001:2008 certified. We test every fan before leaving the factory. All fans are performance tested to ISO 5801:2007 for airflow, ISO 13347.3:2004 or AMCA 300 for sound, and certified to meet the requirements of AS4429:1999 when used as smoke spill fans.

# Supply/Extract Air Fans

## EC Axial



SAF Duct Mounted



RAD Roof Mounted



AW Wall Mounted

## EC Centrifugal

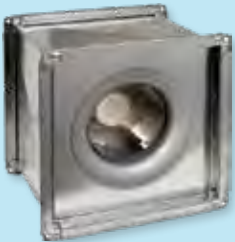

ICQ Duct Mounted

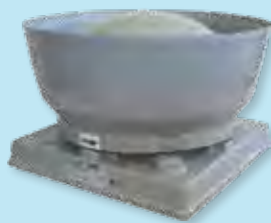

RCV Vertical Discharge

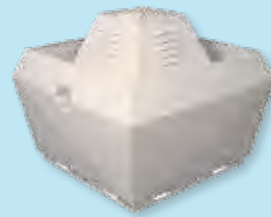

KMV Roof Mounted  
Vertical Discharge

## Axial



AX Duct Mounted



VD Roof Mounted

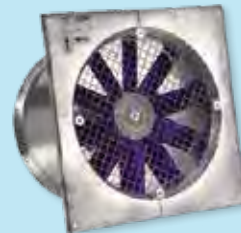

DP Wall Mounted

## Centrifugal and Mixed Flow



ICQ/IMQ Duct Mounted

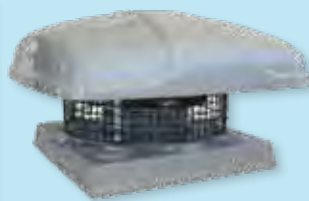

RCD Extract



CS Supply Air

# IntelligentController

The Systemair Pre-programmed control system. Using our **IntelligentController** allows the Jet Fan and sensors to work independently.

The Car Park Ventilation **IntelligentController** enables control of car park fans (exhaust/supply/jet fans) via Modbus dual bus control signals. Multiple zones can be set up using expansion modules, for managing and monitoring car park fans and sensors.

The controller can control up to 256 devices via Modbus Communication. Therefore, the controller can be configured to any requirement.

- Jet Fans – up to 30 EC jet fans in single bus
- CO Modbus sensors – up to 30 sensors in single bus
- Smoke sensors – smoke sensor supplied and connected with Jetfan on request
- 2 analogue output to drive supply/extract fan
- Expansion boards – up to 20
- Fire shutdown integration with manual override control for Jet fans
- Supervisory system – connects high level BMS system via Modbus, BACnet. Allows remote monitoring of system.
- Mechanical Service Switch Board with 4 fault alarms, system OK indication, 3 mechanical switches for jet fans, supply fans and exhaust fans
- Display of CO level in car park
- Purge cycle one in a 24hr period to provide one air change
- Ventilation rate will be varied between 9ppm and 35ppm
- System will be in sleep mode when CO levels are below 9ppm
- System will run at 100% under all fault condition

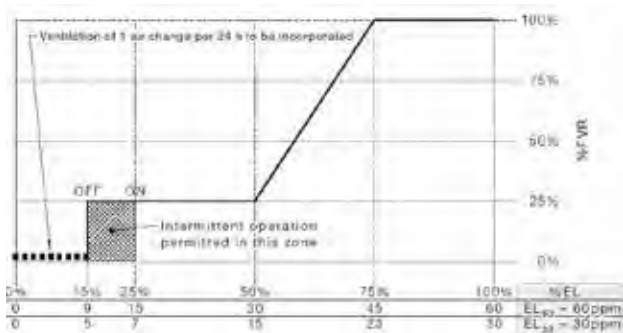

Minimum Ventilation (Extracted from AS1688.2-2012-4.11)



**IntelligentController** with complete enclosure



**IntelligentController**

## Fan Control methods

The controller has two methods for controlling all connected fans. There is a Manual/Off/Auto switch for the exhaust fan allowing the user to control and set to their needs.

### Automatic mode

- All connected fans will be demand driven by the varying CO levels in the car park.
- All connected fans will go in standby mode when CO levels are below 9ppm.
- System will wake up when CO levels are above 9ppm and will vary the fans speed between 20 and 100% of the full speed.

### Manual Mode

- Controller will disregard all sensor inputs and run selected fans at 100% or preselected speed.
- Fan speeds can be adjusted manually through the configuration menu.

The controller operates the car park ventilation system in accordance with AS 1668.2:2012 by checking carbon monoxide levels and regulating the ventilation system. Expansion modules can be added to the system for individual zone control and Mechanical Service Switch Board control (Auto/Off/On). The controller can also be integrated into the building fire system and will operate in accordance with AS 1668.2:2012.

# Block Diagram

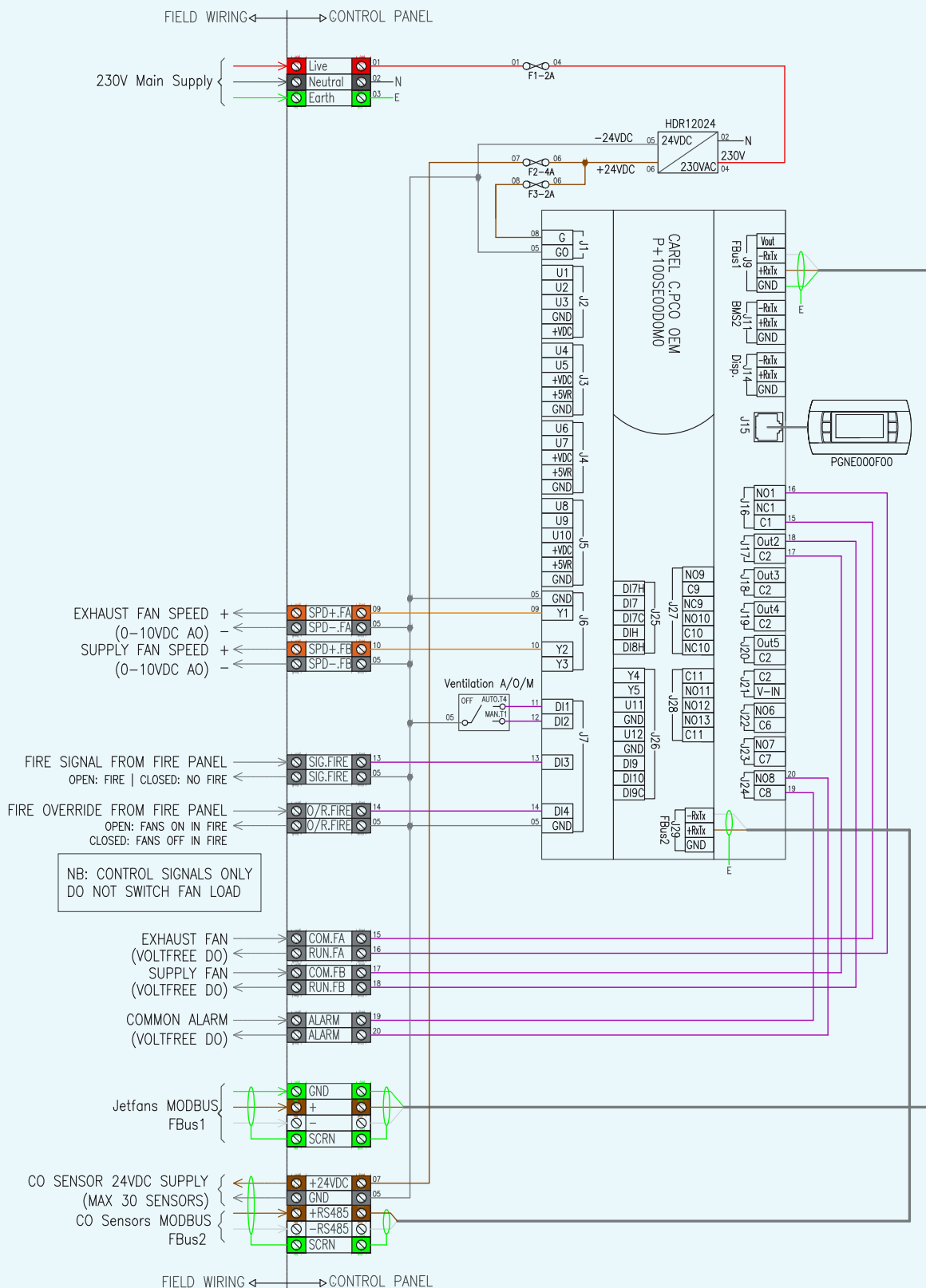

## Technical

Model	Max. JetFans	Max. CO Sensors	Analogue output	Power Output	Input Power	Dimension
CPC-30	30	30	2 x 0-10V	24VDC	230AC	500 x 400 x 200
CPC-15	15	15	2 x 0-10V	24VDC	230AC	500 x 400 x 200



Systemair New Zealand Ltd

Ph 0800 100 326

[nzsales@systemair.com](mailto:nzsales@systemair.com)

[www.systemair.nz](http://www.systemair.nz)